

3 规格 SPECIFICATIONS

1	相数 Number of Phase	4
2	步距角 Step Angle	1.8° ±5%
3	转子惯量 Rotor Inertia	g • cm ²
4	绝缘电阻 Insulation Resistance	100MΩ 500VDC
5	绝缘等级 Insulation Class	B (130℃)
6	环境温度 Ambient Temperature	-20℃ to 50℃
7	环境湿度 Ambient Humidity	15% to 95%
8	电机重量 Motor Weight	Approx xx kg

3 WIRINGS CONNECTION DIAGRAM

	最大静转矩 Holding Torque (2 phases on) N. m±10%	额定电流/相 Rated Current/Phase (Amps DC)	相电阻 Resistance/Phase (ohms) ±10%	电压/相 Voltage/Phase (V DC)	电感/相 Inductance/Phase (mH) ±20% Typical (1kHz)
单极性驱动 Unipolar	4.6	4.2	1.2	5.0	3.4
串接 Bipoar (Series)	6.0	2.97	2.4	7.13	10.2
并接 Bipoar (Parallel)	6.0	5.94	0.6	3.6	2.7

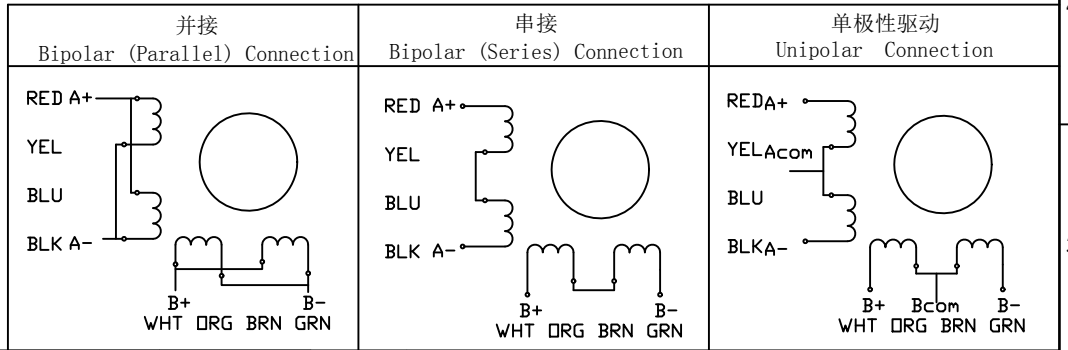

Unit:mm 第一角画法 First angle method 未注线性与角度尺寸公差 Tolerances for linear and angular dimensions without individual tolerance indications GB/T 1804-m eqv ISO 2768-1:m 未注形状与位置尺寸公差 Geometrical tolerances for features without individual tolerance indications GB/T 1184-k eqv ISO 2768-2:k		设计 DESIGN	XH	20190230	CW-motor 	常州创伟电机电器有限公司 Changzhou Chuangwei Motor & Electric Apparatus Co.,Ltd			
V1.0		校核 CHECK							
REV.		工艺 TECHNOLOGY			Model: 86BHH97-420E-Y37J ①				
版本记录 REVISION RECORD		标准化 STANDARD							
DATE		批准 APPROVE							
UNLESS OTHERWISE SPECIFIDE		NAMES	SINGATURE	DATE					