

# HEDY

## HD700 User Manual

(0.4kW~500kW)



(V1.5)

# Foreword

Thanks for your choosing HD700 AC Drive from HEDY company.

This manual introduces installation, setup and commissioning of HD700 Drive, also troubleshooting and maintenance. This ***HD700 User Manual*** is for easy and efficient operating. For further technical information and guide, you can download the ***HD700 Advanced User Manual*** from the website: <http://www.hedyi.com>

We will update and improve the manual termly, and this document is subject to change without notice.

Copyright © 2015 by Guangzhou HEDY Intelligent Equipment Co., Ltd.

All rights reserved.

Please read the information carefully, and keep the manual, please make sure that the end customer has the manual.

# Contents

<b>Warnings, Cautions and Notes</b> .....	<b>I</b>
<b>1 Technical specification</b> .....	<b>1</b>
1.1 Model reference.....	1
1.2 Rating Label .....	1
1.3 Power size.....	2
1.4 General technical data.....	4
<b>2 Installation and cabling</b> .....	<b>8</b>
2.1 Dimension .....	8
2.1.1 Parts of drive.....	8
2.1.2 Diagram of mounting.....	8
2.1.3 Keypad pallet.....	13
2.1.4 Simple keypad pallet.....	15
2.1.5 External DC reactor dimensions .....	16
2.2 Mechanical installation.....	18
2.2.1 Drive installation diagram.....	18
2.2.2 How to fit and remove the terminal cover.....	19
2.2.3 How to fit and remove the keypad .....	20
2.3 Electrical installation .....	20
2.3.1 Power terminals .....	20
2.3.2 Power connections .....	26
2.3.3 Typical cabling.....	30
2.3.4 Control terminals specification .....	31
2.3.5 Brake resistor.....	38
2.3.6 EMC Guide.....	40
2.3.7 EMC Filter.....	40
<b>3 Operation and display</b> .....	<b>46</b>
3.1 Keypad .....	46
3.1.1 LED lights.....	46
3.1.2 Key function .....	47
3.1.3 Keypad operation.....	48

3.2	Drive control .....	52
3.2.1	Drive status .....	52
3.2.2	Control modes .....	53
3.2.3	Reference source .....	53
3.2.4	Priority of running mode .....	54
3.3	Quick commissioning .....	54
3.3.1	Keypad control .....	54
3.3.2	Terminal control .....	55
4	Parameters .....	58
4.1	General description .....	58
4.3	Menu P00 .....	59
5	Troubleshooting .....	67
5.1	Faults and corrective actions .....	67
5.2	Alarms .....	75
5.3	Other issues .....	76
6	Maintenance .....	78
6.1	Routine maintenance .....	78
6.2	Periodic check .....	78
6.3	Parts replacement .....	80
6.4	Drive storage .....	80
6.5	Disposal .....	80
Appendix	.....	81
1	Communication .....	81
2	Parameter list .....	90
	Menu P00: Shortcut menu (quick commissioning) .....	90
	Menu P01: Reference .....	94
	Menu P02: Ramp .....	97
	Menu P03: Start and stop .....	100
	Menu P04: Preset and PLC .....	103
	Menu P05: Keypad and display .....	108
	Menu P06: V/F controls parameters .....	111
	Menu P07: Vector .....	112
	Menu P08: Analogue input and output .....	114

Menu P09: Digital input and output.....118

Menu P10: Comms. and general function..... 123

Menu P11: Fault Tracking ..... 126

Menu P12: Protection ..... 127

Menu P13: Motor..... 129

Menu P14: Textile function ..... 132

Menu P15: PID Controller..... 134

Menu P16: Programmable logic and binary sum ..... 137

Menu P17: Threshold and variable selector ..... 139

Menu P18: Brake logic control ..... 144

3 Multistage velocity setup guide ..... 145

4 Options ..... 149

5 Declaration of conformity..... 150

Drive Repair Card..... 152

Service Agreement ..... 153

# Warnings, Cautions and Notes



## Warning:

A **Warning** contains information, which is essential for avoiding a safety hazard.



## Caution:

A **Caution** contains information, which is necessary for avoiding risk of damage to the product or other equipment.

## NOTE

A **Note** contains information, which helps to ensure correct operation of the product.



## WARNING

- The HD700 AC drive should **ONLY** be installed by a qualified electrician.
- Install the drive on nonflammable materials like metalsheet in case of fire.
- Do not install the drive in environment with explosive gas.
- Even when the motor is stopped, dangerous voltage is present at the Power Circuit terminals L1, L2, L3, U, V, W ,and,depending on the frame size, DC+ and DC-, or BR.
- Dangerous voltage is present when input power supply is connected to the drive. After disconnecting the supply, wait at least 10 minutes (to let the intermediate circuit capacitors discharge) before removing the cover.
- PE terminals must be earthed very well.

 **CAUTION**

- The HD700 is not a field repairable unit. Never attempt to repair a malfunctioning unit; contact the factory or your local Authorized Service Center for replacement.
- The HD700 will start up automatically after an input voltage interruption if external running command is on.
- Prior to measurements on the motor or the motor cable, disconnect the motor cable from the Variable Speed Drive.
- Before connecting the Variable Speed Drive to mains, make sure that the HD700's front cover and cable cover are closed.

# 1 Technical specification

## 1.1 Model reference

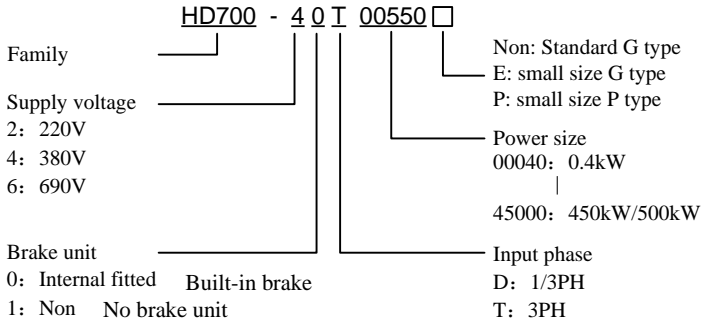

Figure1-1 HD700 model description

## 1.2 Rating Label

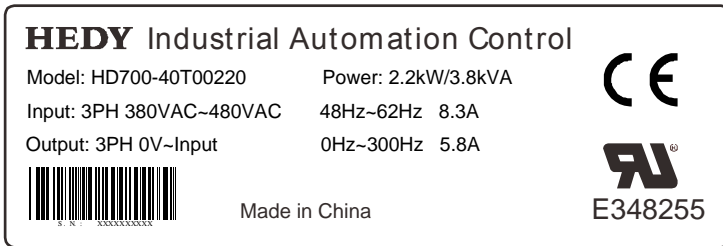

Figure1-2 HD700 rating label (Single power type)

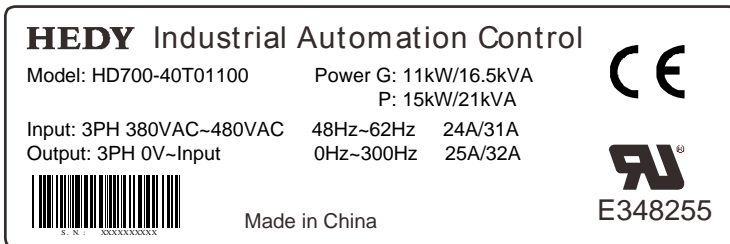

Figure1-3 HD700 rating label (Double power type)

NOTE: Size A, B, C are single types. Size D and above are G/P types.



### 1.3 Power size

Power size of HD700 is based on the standard 4 poles inductionmotor at rated voltage.

E, G: Heavy duty

P: Normal duty

Overload of E, G type: 150% rated output current, 1 minute

Overload of P type: 110% rated output current, 1 minute

Table 1-1 220V rating data

Power supply: 200Vac~240Vac, 50Hz/60Hz, single/three phase						
Model	Default carrier frequency (kHz)	Drive Power Size (kVA)	Rated Input Current (A)	Rated Output Current (A)	Motor Power (kW)	Size
			1/3PH			
HD700-20D00040	6	1.1	7.1/4	2.8	0.4	A
HD700-20D00075	6	1.9	12.8/7.1	5	0.75	A
HD700-20D00150	6	3.0	20.5/11.3	8	1.5	A
HD700-20D00220	6	4.2	24/14.5	11	2.2	B
HD700-20D00400	6	6.7	30.4/16.5	17.6	4	C

Table 1-2 380V rating data

Power supply: 380Vac~480Vac, 50Hz, three phase										
Model	Default carrier frequency (kHz)	G				P				Size
		Drive Power Size (kVA)	Rated Input Current (A)	Rated Output Current (A)	Motor Power (kW)	Drive Power Size (kVA)	Rated Input Current (A)	Rated Output Current (A)	Motor Power (kW)	
HD700-40T00075	6	1.7	3.6	2.5	0.75	-	-	-	-	A
HD700-40T00150	6	2.8	5.7	4.2	1.5	-	-	-	-	A
HD700-40T00220E	6	3.4	6.1	5.2	2.2					A
HD700-40T00220	6	3.8	8.3	5.8	2.2	-	-	-	-	B
HD700-40T00400	6	6.3	13.2	9.5	3.7	-	-	-	-	B
HD700-40T00550E	6	8.6	14.3	13	5.5	-	-	-	-	B
HD700-40T00550P	6	-	-	-	-	8.6	14.3	13	5.5	B
HD700-40T00550	6	8.6	12.4	13	5.5	-	-	-	-	C
HD700-40T00750	6	11	16.1	17	7.5	-	-	-	-	C
HD700-40T01100P	6	-	-	-	-	15.2	21	23	11	C
HD700-40T01100	6	16.5	24	25	11	21	31	32	15	D
HD700-40T01500	6	21	31	32	15	25	36	38	18.5	D
HD700-40T01850	6	25	36	38	18.5	30	44	46	22	E
HD700-40T02200	6	30	44	46	22	40	58	60	30	E
HD700-40T03000E	3	40	58	60	30	50	72	75	37	E1

Power supply: 380Vac~480Vac, 50Hz, three phase										
Model	Default carrier frequency (kHz)	G				P				Size
		Drive Power Size (kVA)	Rated Input Current (A)	Rated Output Current (A)	Motor Power (kW)	Drive Power Size (kVA)	Rated Input Current (A)	Rated Output Current (A)	Motor Power (kW)	
HD700-40T03700E	3	50	72	75	37	—	—	—	—	E1
HD700-40T03000	3	40	58	60	30	50	72	75	37	F
HD700-40T03700	3	50	72	75	37	63	93	96	45	F
HD700-40T04500	3	63	93	96	45	83	121	125	55	F
HD700-40T05500	3	83	121	125	55	103	151	156	75	F
HD700-40T07500	3	103	151	156	75	119	175	180	90	F
HD700-40T09000	3	119	175	180	90	139	204	210	110	G
HD700-40T11000	3	139	204	210	110	169	248	256	132	G
HD700-40T13200	3	169	248	256	132	205	301	310 <sub>#</sub>	160	G
HD700-40T16000E	3	205	301	310	160	231	340	350	185	J
HD700-40T18500E	3	231	340	350	185	255	375	387	200	J
HD700-40T20000E	3	255	375	387	200	280	415	427	220	J
HD700-40T16000	3	205	301	310	160	231	340	350	185	K
HD700-40T18500	3	231	340	350	185	255	375	387	200	K
HD700-40T20000	3	255	375	387	200	310	457	471	250	K
HD700-40T25000	3	310	457	471	250	343	505	520	280	K
HD700-40T28000	3	343	505	520	280	403	592	610	315	K
HD700-40T31500E	2	403	592	610	315	444	653	673	355	K1
HD700-40T35500E	2	444	653	673	355	495	728	750	400	K1
HD700-40T31500	2	403	592	610	315	444	653	673	355	L
HD700-40T35500	2	444	653	673	355	495	728	750	400	L
HD700-40T40000	2	495	728	750	400	551	810	835	450	L
HD700-40T45000	2	551	810	835	450	622	915	943	500	L

Table 1-3 690V rating data

Power supply: 500Vac~690Vac, 50Hz, three phase										
Model	Default carrier frequency (kHz)	G				P				Size
		Drive Power Size (kVA)	Rated Input Current (A)	Rated Output Current (A)	Motor Power (kW)	Drive Power Size (kVA)	Rated Input Current (A)	Rated Output Current (A)	Motor Power (kW)	
HD700-60T03000	3	43	36	36	30	51	42	43	37	F
HD700-60T03700	3	51	42	43	37	65	52	54	45	F
HD700-60T04500	3	65	52	54	45	75	61	63	55	F
HD700-60T05500	3	75	61	63	55	103	83	86	75	F
HD700-60T07500	3	103	83	86	75	120	97	100	90	F

Power supply: 500Vac~690Vac, 50Hz, three phase										
Model	Default carrier frequency (kHz)	G				P				Size
		Drive Power Size (kVA)	Rated Input Current (A)	Rated Output Current (A)	Motor Power (kW)	Drive Power Size (kVA)	Rated Input Current (A)	Rated Output Current (A)	Motor Power (kW)	
HD700-60T09000	3	120	97	100	90	157	127	131	110	G
HD700-60T11000	3	157	127	131	110	179	145	150	132	G
HD700-60T13200	3	179	145	150	132	209	170	175 <sub>註</sub>	160	G
HD700-60T16000E	3	209	170	175	160	237	192	198	185	J
HD700-60T18500E	3	237	192	198	185	276	224	231	200	J
HD700-60T20000E	3	276	224	231	200	296	235	248	220	J
HD700-60T16000	3	209	170	175	160	237	192	198	185	K
HD700-60T18500	3	237	192	198	185	276	224	231	200	K
HD700-60T20000	3	276	224	231	200	327	266	274	250	K
HD700-60T25000	3	327	266	274	250	350	285	293	280	K
HD700-60T28000	3	350	285	293	280	392	318	328	315	K
HD700-60T31500E	2	392	318	328	315	462	375	387	355	K1
HD700-60T35500E	2	462	375	387	355	509	413	426	400	K1
HD700-60T31500	2	392	318	328	315	462	375	387	355	L
HD700-60T35500	2	462	375	387	355	509	413	426	400	L
HD700-60T40000	2	509	413	426	400	576	468	482	450	L
HD700-60T45000	2	576	468	482	450	651	529	545	500	L

NOTE:

- HD700- $\times$ IT $\times\times\times\times$  rating data are the same with HD700- $\times$ OT $\times\times\times\times$ .
- For 30kW and above models, internal brake unit is optional, please refer to chapter 1.1.
- When HD700- $\times$ T13200 or HD700- $\times$ T28000 is used as P type, the default carrier frequency is 1kHz.

### 1.4 General technical data

Table 1-4 General technical specification

Input Power	Input Voltage $U_{in}$	200V (-10%)~240V (+10%) 380V (-10%)~480V (+10%) 500V (-10%)~690V (+10%)	1/3 PH 3PH 3PH
	Input Frequency	50/60Hz ( $\pm$ 2Hz)	
	Maximum Supply Imbalance	$\leq$ 3%	
Power Output	Output Voltage	0V~ $U_{in}$	
	Output Frequency	0Hz~300Hz	

<b>Main Performance Function</b>	<b>Voltage Control</b>	V/F, Open loop Vector Control
	<b>Switching Frequency</b>	1kHz~15kHz
	<b>Speed Adjustment Range</b>	Open loop vector -1:100, V/F mode -1:50
	<b>Start Torque</b>	0.5Hz: 100% rated torque, 1Hz: 150% rated torque
	<b>Torque Accuracy</b>	7%
	<b>Reference resolution</b>	Digit- 0.01Hz, Analogue- 0.1% ×Max. frequency
	<b>Acce. &amp; Dece. rate</b>	0.1s~3600min
	<b>Voltage Boost</b>	0.1%~30.0%
	<b>Overload</b>	E, G type: 150% rated output current, 1 minute P type: 110% rated output current, 1 minute
	<b>V/F</b>	4 types: V/F (user can program) and ramp (2.0 power, 1.7 power, 1.2 power)
	<b>DC Braking</b>	Injection frequency: 0.0%~100.0% Max. frequency Injection current: 0.0%~300.0% rated current Injection time: 0.00s~60.00s
	<b>Dynamic Brake</b>	Brake rate: 0.0%~100.0%
	<b>Jog</b>	Jog frequency: 0.00Hz~maximum frequency Jog acceleration rate: 0.1s~600.0s Jog interval time: 0.1s~600.0s
	<b>Preset</b>	16 preset speeds (decided by control terminals)
<b>AVR</b>	Maintain the rated output voltage when the input power supply voltage changed	
<b>Special Function</b>	<b>Textile</b>	For textile machine control
	<b>Simple PLC</b>	Onboard PLC
	<b>Length Control</b>	Winding control
	<b>PID Control</b>	Process control (reference close loop control)
	<b>Advanced Function Blocks</b>	2 logic control blocks, 1 binary selector, 2 threshold control blocks, 3 variable selectors

<b>Control Terminal</b>	<b>Reference Source</b>	Digit: Keypad, motorized pot (E-Pot), preset speed, pulse, comms.
		Analogue: AI1: 0V~10V, 0(4) mA~20mA; AI2: 0V~10V
	<b>Operating Mode</b>	Keypad, Control terminal, Serial comms.
	<b>Digital Input Terminals</b>	DI1~DI7: Programmable terminals and DI6 can be set as pulse input, 0Hz~60Hz; DI7 can be high frequency pulse input (1kHz~50.0kHz) or PTC thermistor input
	<b>Digital output terminals</b>	DO1~DO2: Programmable terminals, Max. output current: 50mA, DO2 can be the terminal of output pulse (0.1kHz~50.0kHz), and output PWM
	<b>Analogue output</b>	AO1: programmable terminal, 0V~10V
<b>Comms.</b>	<b>Status relay</b>	2 programmable relays, contactor data: AC250V/2A(COSφ=1) AC250V/1A(COSφ=0.4) DC30V/1A
	<b>Connector</b>	2 terminals (A&B) and RJ45 Port
<b>Environment</b>	<b>Protocol</b>	Modbus RTU
	<b>Altitude</b>	1000m rated 1000m~3000m, 1% rated current derating per 100m
	<b>Operating Temperature</b>	-10°C~+40°C
	<b>Max. Humidity</b>	≤90%RH, no-condensing
	<b>Vibration</b>	≤5.9m/s <sup>2</sup> (0.6g)
	<b>Storage Temperature</b>	-40°C~+70°C
<b>Running Environment</b>	Indoor, no-flammable or corrosive gasses, no contamination with electrically conductive materials, avoiding dust which may restrict the fan	

<b>Optional Module</b>	LCD keypad, HDOM-232, HDOM-USB, Profibus module, keypad pallet, HDSOFT (PCTools), etc.
<b>Protection Function</b>	Output shortage, over current, over load, over voltage, under Voltage, Phase loss, over heat (heatsink and junction), external fault, etc.
<b>Efficiency</b>	1.5kW and below: $\geq 89\%$ 2.2kW~22kW: $\geq 93\%$ 30kW and above: $\geq 95\%$
<b>Installation</b>	can be installed by hanging wall, through holes, or vertically
<b>Ingress Protection</b>	IP20, IP21 (by adding optional device)
<b>Cooling Method</b>	220V/0.4kW model – cools naturally, others cool with forced air cool

## 2 Installation and cabling

### 2.1 Dimension

#### 2.1.1 Parts of drive

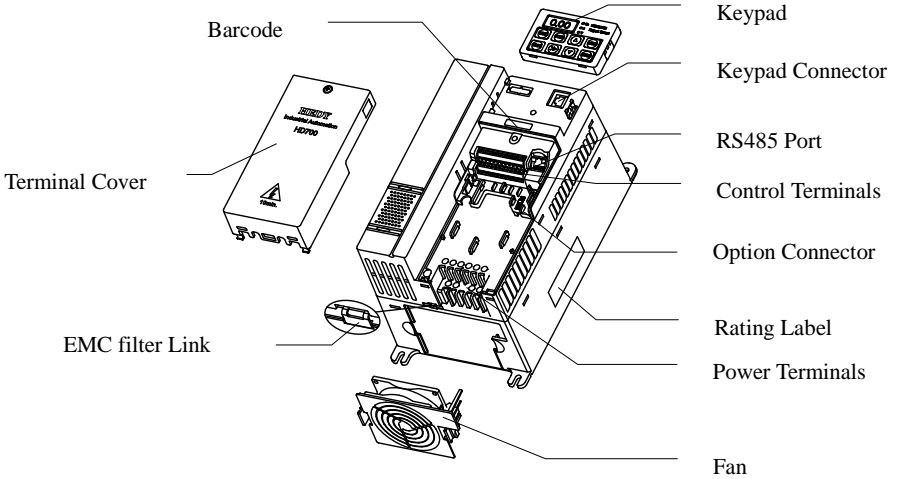

Figure 2-1 Parts of HD700 drive

#### 2.1.2 Diagram of mounting

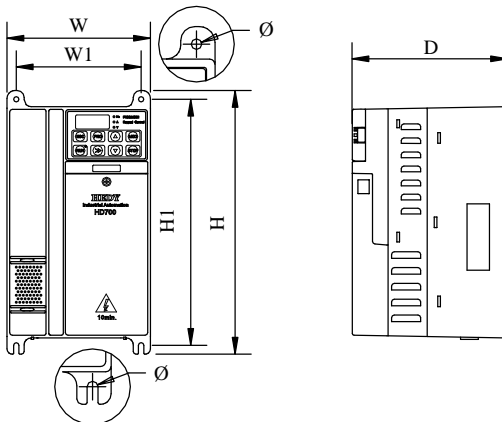

Figure 2-2 Mechanical dimensions and mounting (Size A, B, C)

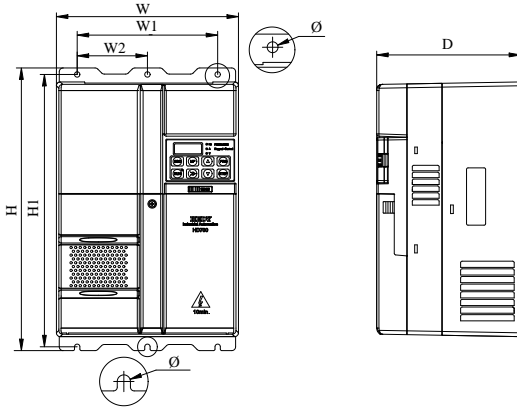

Figure 2-3 Mechanical dimensions and mounting (Size D, E)

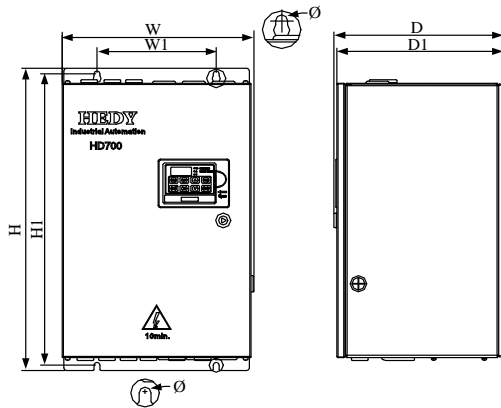

Figure 2-4 Mechanical dimensions and mounting (Size E1, F)

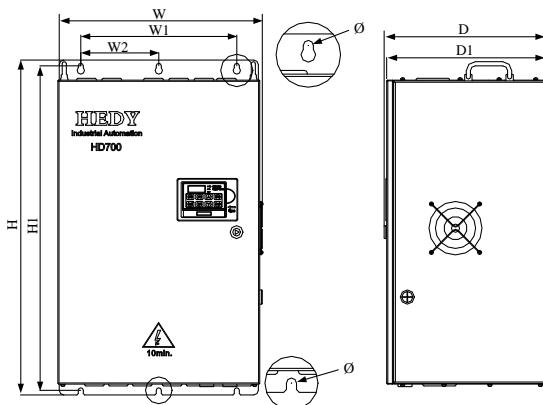

Figure 2-5 Mechanical dimensions and mounting (Size G)



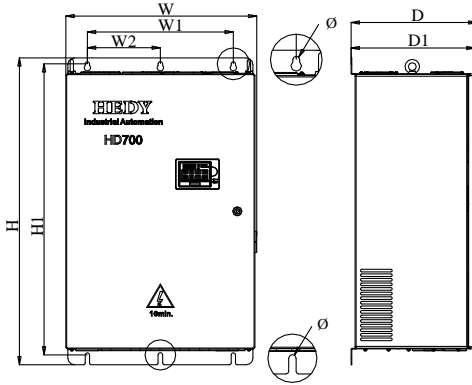

Figure 2-6 Mechanical dimensions and mounting (Size J)

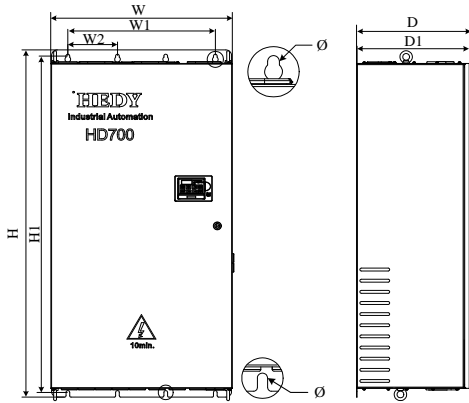

Figure 2-7 Mechanical dimensions and mounting (Size J)

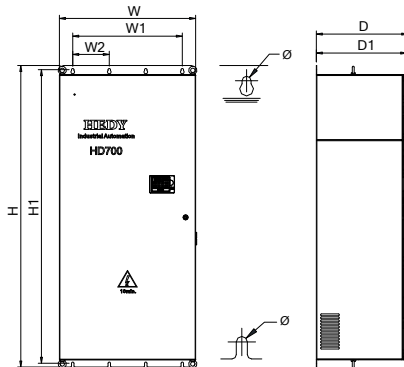

Figure 2-8 Mechanical dimensions and mounting (Size K1)

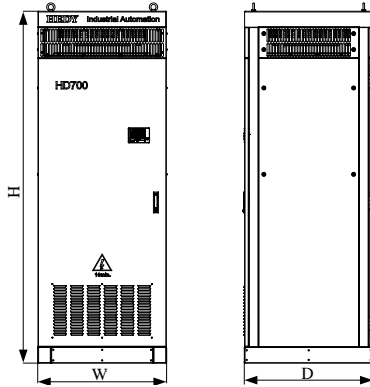

Figure 2-9 Mechanical dimensions and mounting (Size L)

Table 2-1 Mechanical dimensions

Size	Model Name	W (mm)	W1 (mm)	W2 (mm)	H (mm)	H1 (mm)	D (mm)	D1 (mm)	Mounting Hole Ø	Weight (kg)
A	HD700-20D00040	97.4	80	-	202.4	190	148.8	-	5	1.4
	HD700-20D00075									
	HD700-20D00150									
	HD700-40T00075									
	HD700-40T00150									
HD700-40T00220E										
B	HD700-20D00220	142.4	123.5	-	220.4	208	155.5	-	5	2.2
	HD700-40T00220									
	HD700-40T00400									
	HD700-40T00550E									
	HD700-40T00550P									
C	HD700-20D00400	163.1	142	-	300	280	176.8	-	6	4.5
	HD700-40T00550									
	HD700-40T00750									
	HD700-40T01100P									
D	HD700-40T01100	238.5	184	92	370	356.5	189	-	7	8.8
	HD700-40T01500									
E	HD700-40T01850	238.5	184	92	435.5	422	200.3	-	7	12.1
	HD700-40T02200									
E1	HD700-40T03000E	320	210	-	510	490	226	222.5	8	20
	HD700-40T03700E									

2 Installation and cabling

Size	Model Name	W (mm)	W1 (mm)	W2 (mm)	H (mm)	H1 (mm)	D (mm)	D1 (mm)	Mounting Hole Ø	Weight (kg)
F	HD700-40T03000	355.5	221	-	573	552.5	315.5	310	10	40
	HD700-40T03700									
	HD700-40T04500									
	HD700-40T05500									
	HD700-40T07500									
	HD700-60T03000									
	HD700-60T03700									
	HD700-60T04500									
	HD700-60T05500									
	HD700-60T07500									
G	HD700-40T09000	445.6	340	170	725	701.5	355	349.5	10	63
	HD700-40T11000									
	HD700-40T13200									
	HD700-60T09000									
	HD700-60T11000									
	HD700-60T13200									
J	HD700-40T16000E	575.5	440	220	937	889	379.3	373.8	13	104
	HD700-40T18500E									
	HD700-40T20000E									
	HD700-60T16000E									
	HD700-60T18500E									
	HD700-60T20000E									
K	HD700-40T16000	640	520	175	1246.5	1207.5	405.5	400	13	150
	HD700-40T18500									
	HD700-40T20000									
	HD700-40T25000									
	HD700-40T28000									
	HD700-60T16000									
	HD700-60T18500									
	HD700-60T20000									
	HD700-60T25000									
	HD700-60T28000									

Size	Model Name	W (mm)	W1 (mm)	W2 (mm)	H (mm)	H1 (mm)	D (mm)	D1 (mm)	Mounting Hole Ø	Weight (kg)
K1	HD700-40T31500E	720	579	194	1595.5	1553.5	483	477.5	13	-
	HD700-40T35500E									
	HD700-60T31500E									
	HD700-60T35500E									
L	HD700-40T31500	804	-	-	2200	-	804	-	-	350
	HD700-40T35500									
	HD700-40T40000									
	HD700-40T45000									
	HD700-60T31500									
	HD700-60T35500									
	HD700-60T40000									
HD700-60T45000										

### 2.1.3 Keypad pallet

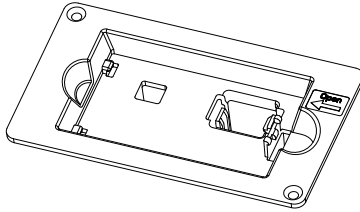

Figure 2-10 Outlook of keypad pallet

Diagram of pallet dimensions and mounting

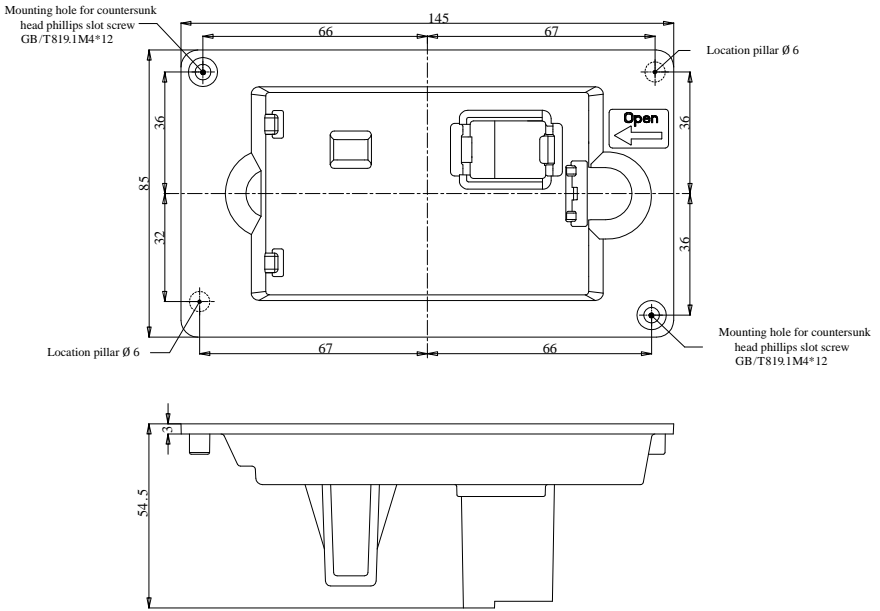

Figure 2-11 Outline dimensions of pallet

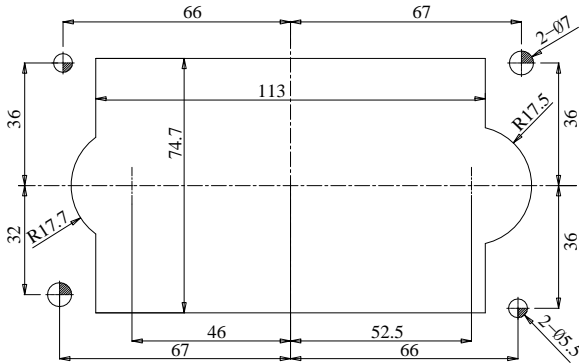

Figure 2-12 mounting dimensions of pallet

## 2.1.4 Simple keypad pallet

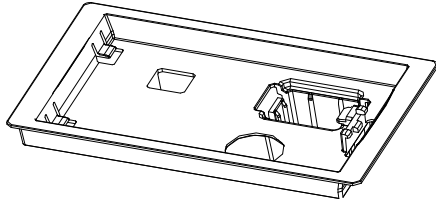

Figure 2-13 Outlook of Simple keypad pallet

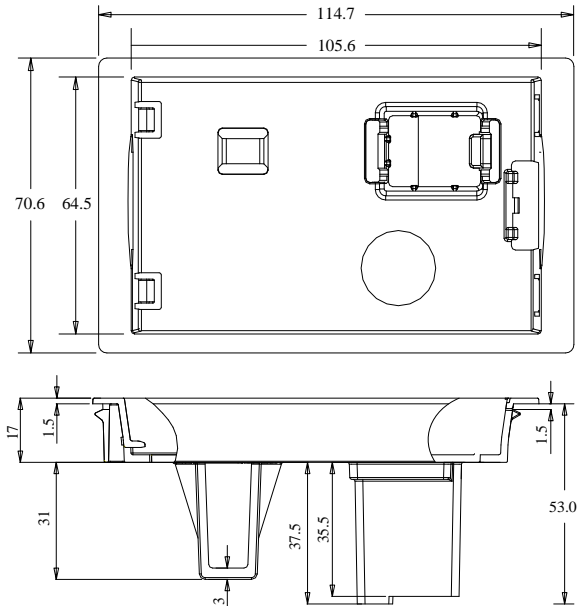

Figure 2-14 Outline dimensions of simple keypad pallet

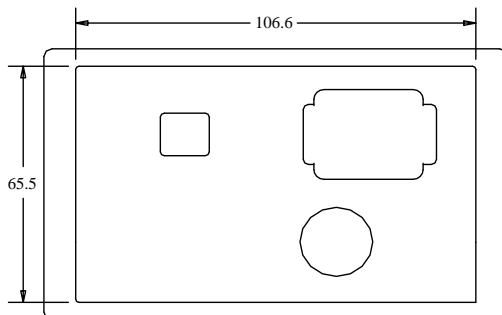

Figure 2-15 Mounting dimensions of Simple keypad pallet

2.1.5 External DC reactor dimensions

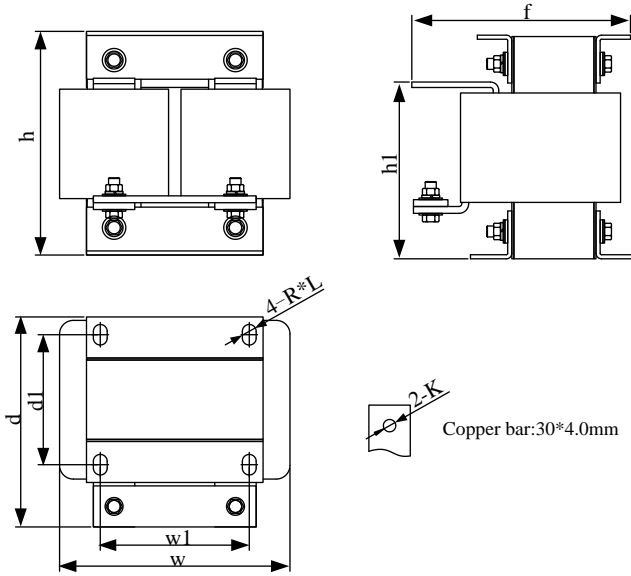

Figure 2-16 External DC reactor dimensions

Table 2-2 380V DC reactor dimensions (Unit: mm)

Model	w	w1	d	d1	h	h1	f	Mounting hole R*L	Copper bar mounting hole K	Reactor weight (kg)
HD700-40T05500	167	108	153.5	95	163.5	131	158.5	10×15	Ø9	10.3
HD700-40T07500										
HD700-40T09000	190	160	153	117	245	192	180	10×15	Ø12	20
HD700-40T11000										
HD700-40T13200										
HD700-40T16000E	190	160	148	115	245	192	250	10×20	Ø13	25
HD700-40T18500E										
HD700-40T20000E										
HD700-40T16000	275	210	240	205	235	-	240	11×18	Ø14	38
HD700-40T18500										
HD700-40T20000										
HD700-40T25000										
HD700-40T28000										

Table 2-3 690V DC reactor dimensions (Unit: mm)

Model -	w	w1	d	d1	h	h1	f	Mounting hole R*L	Copper bar mounting hole K	Reactor weight (kg)
HD700-60T05500	128	100	116	90	180	140	175	10×15	Ø9	10
HD700-60T07500										
HD700-60T09000	190	160	153	117	245	192	180	10×15	Ø12	20
HD700-60T11000										
HD700-60T13200										
HD700-60T16000E	190	160	148	115	245	192	250	10×20	Ø13	25
HD700-60T18500E										
HD700-60T20000E										
HD700-60T16000	235	180	230	175	205	-	230	11×18	Ø14	27.5
HD700-60T18500										
HD700-60T20000										
HD700-60T25000										
HD700-60T28000										

Note: 1.Reactors of HD700-40T31500E and HD700-40T35500E are AC Reactor, whose dimensions are as follows:

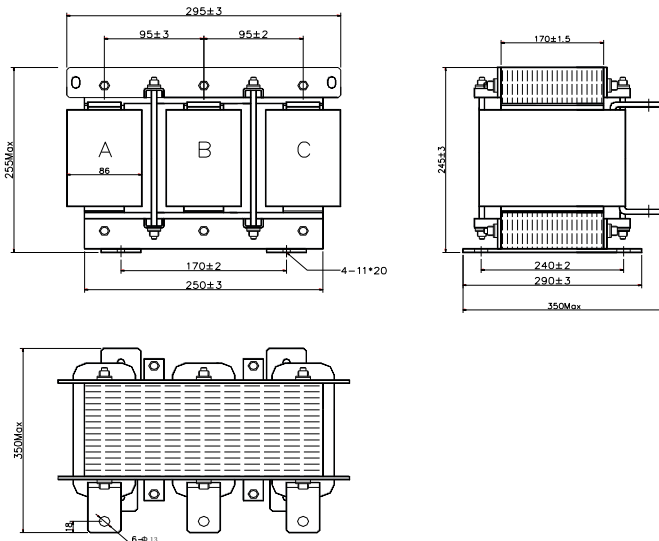

Figure 2-17 Dimensions of External AC/DC Reactor (Size K1,380V\_)



Note: 2.Reactors of HD700-60T31500E and HD700-60T35500E are AC Reactor, whose dimensions are as follows:

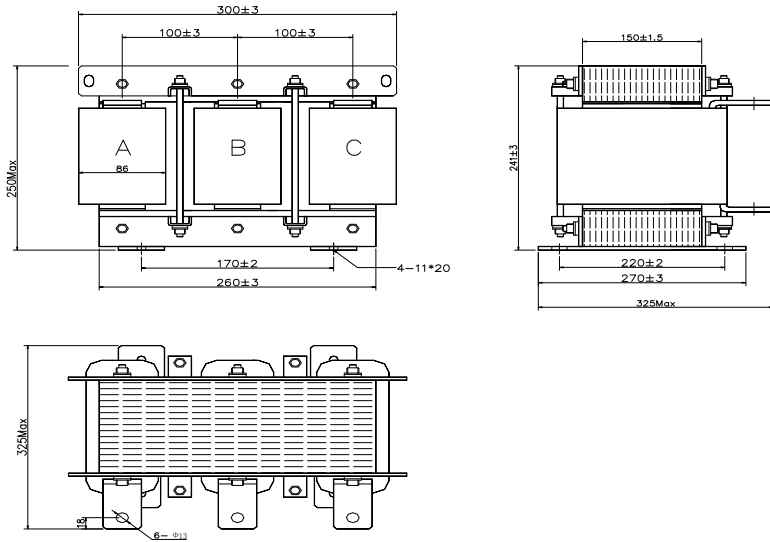

Figure 2-18 Dimensions of External AC/DC Reactor (Size K1,690V\_)

## 2.2 Mechanical installation

### 2.2.1 Drive installation diagram

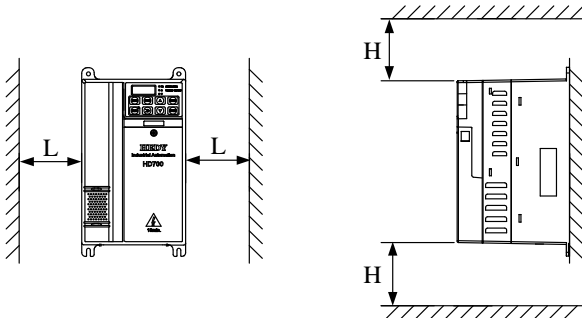

Figure 2-19 Single drive installation  
 Recommending:  $L \geq 50 \text{mm}$ ,  $H \geq 50 \text{mm}$

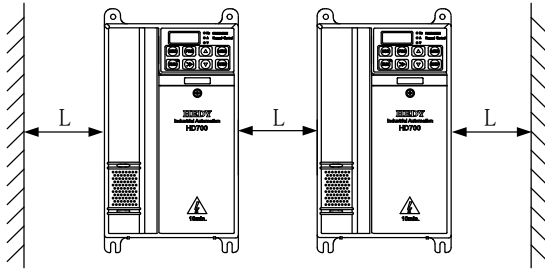

Figure 2-20 Multi-drives installation

Recommending:  $L \geq 50\text{mm}$

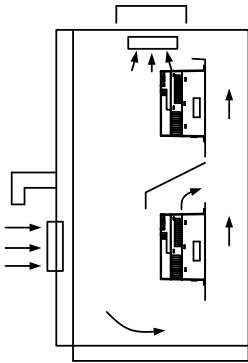

Figure 2-21 Multi drives vertical installation

NOTE: In vertical installations where drives are mounted above each other, there should be suitable air flow to keep the drives cool. Air flow should be drawn in and expelled as illustrated in the left picture.

## 2.2.2 How to fit and remove the terminal cover

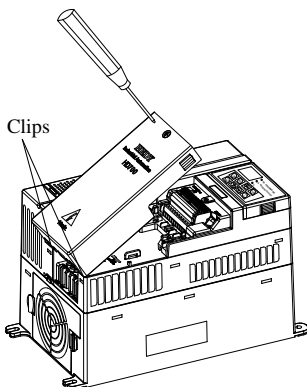
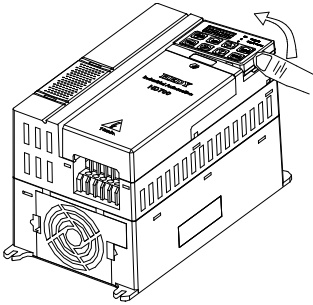

Figure 2-22 Terminal cover fitting and removes

Remove: Untighten the screw, loose the clip then take off the cover.

Fit: at a suitable angle, put the clips into the slots on the middle cover, push the cover on, tighten the screw M4×10 (Torque 1N m).

### 2.2.3 How to fit and remove the keypad



Remove: push the spring clip, and then pull up the keypad.

Fit: fit the left two clips (at correct angle) into the slots on the control pod, and then push down the keypad.

Figure 2-23 Diagram of the keypad fitting and removing

HD700 keypad is removable, and can be linked to the drive with a standard net cable -, shown as below:

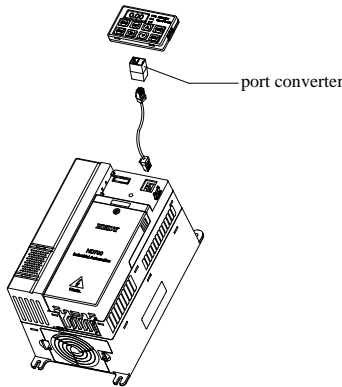

Figure 2-24 Keypad with cable

NOTE: The maximum length of cable is 10m.

## 2.3 Electrical installation

### 2.3.1 Power terminals

◆ Models of size A, B, C: HD700-20D00040~HD700-40T00750

<b>L1</b>	<b>L2</b>	<b>L3/N</b>	<b>U</b>	<b>V</b>	<b>W</b>
<b>PE</b>	<b>+DC</b>	<b>+DC1</b>	<b>BR</b>	<b>-DC</b>	<b>PE</b>

Figure 2-25 Size A, B power terminals layout

<b>L1</b>	<b>L2</b>	<b>L3</b>	<b>U</b>	<b>V</b>	<b>W</b>
<b>PE</b>	<b>+DC</b>		<b>BR</b>	<b>-DC</b>	<b>PE</b>

Figure 2-26 Size C power terminals layout

Table 2-4 Power terminal functions of size A, B, C

<b>Terminals</b>	<b>Functions</b>
L1, L2, L3/N	AC power supply. For single phase supply, L1 and L3/N are suggested
+DC, +DC1	For DC reactor, linked by terminal
BR	Brake resistor, the other side of the resistor is connected to +DC1
-DC	Negative DC bus
U, V, W	Output terminals (Motor terminals)
PE	Protective earth terminal

NOTE:

- Size C has DC reactor inside, +DC1 is not used.
- For size C, the brake resistor is connected to BR and +DC.

◆ Models of size D, E: HD700-40T01100~HD700-40T02200

<b>+DC</b>	<b>BR</b>	<b>-DC</b>	<b>L1</b>	<b>L2</b>	<b>L3</b>	<b>PE</b>	<b>PE</b>	<b>U</b>	<b>V</b>	<b>W</b>
------------	-----------	------------	-----------	-----------	-----------	-----------	-----------	----------	----------	----------

Figure 2-27 Size D, E power terminals layout

Table 2-5 Power terminal functions of size D, E

<b>Terminals</b>	<b>Functions</b>
L1, L2, L3	AC power supply
+DC, -DC	Positive and negative DC bus
BR	Brake resistor, the other side of the resistor is connected to +DC
U, V, W	Output terminals (Motor terminals)
PE	Protective earth terminal

- ◆ Models of size E1: HD700-xxT03000E~HD700-xxT03700E

	<b>+DC</b>	<b>+DC1</b>	<b>L1</b>	<b>L2</b>	<b>L3</b>	<b>PE</b>
<b>Size E1</b>						
<b>BR</b>	<b>+DC</b>	<b>-DC</b>	<b>U</b>	<b>V</b>	<b>W</b>	<b>PE</b>

Figure 2-28 Size E1 power terminals layout

Table 2-6 Power terminal functions of size E1

<b>Terminals</b>	<b>Functions</b>
L1, L2, L3	AC power supply
+DC, +DC1	For DCreactor, linked by busbar from factory
BR	Brake resistor, the other side of the resistor is connected to +DC
-DC	Negative DC bus
U, V, W	Output terminals (Motor terminals)
PE	Protective earth terminal

- ◆ Models of size F: HD700-xxT03000~HD700-xxT04500

			<b>PE</b>	<b>L1</b>	<b>L2</b>	<b>L3</b>
<b>Size F</b>						
<b>BR</b>	<b>+DC</b>	<b>-DC</b>	<b>PE</b>	<b>U</b>	<b>V</b>	<b>W</b>

Figure 2-29 Power terminal of size F

Table 2-7 Power terminal of size F

<b>Terminals</b>	<b>Function</b>
L1, L2, L3	AC power supply
+DC, -DC	Positive and negative DC bus
BR	Brake resistor, the other side of the resistor is connected to +DC
U, V, W	Output terminals (Motor terminals)
PE	Protective earth terminal

- ◆ Models of size F: HD700-xxT05500~HD700-xxT07500

<b>PE</b>	<b>+DC</b>	<b>+DC1</b>		<b>L1</b>	<b>L2</b>	<b>L3</b>
<b>Size F</b>						
<b>BR</b>	<b>+DC</b>	<b>-DC</b>	<b>PE</b>	<b>U</b>	<b>V</b>	<b>W</b>

Figure 2-30 Power terminal of size F

Table 2-8 Power terminal of size F

<b>Terminals</b>	<b>Function</b>
L1, L2, L3	AC power supply
+DC, +DC1	For DC reactor
BR	Brake resistor, the other side of the resistor is connected to +DC1
-DC	Negative DC bus
U, V, W	Output terminals (Motor terminals)
PE	Protective earth terminal

- ◆ Models of size G: HD700-xxT09000~HD700-xxT13200

<b>+DC</b>	<b>+DC1</b>		<b>L1</b>	<b>L2</b>	<b>L3</b>	<b>PE</b>
<b>Size G</b>						
<b>BR</b>	<b>+DC</b>	<b>-DC</b>	<b>U</b>	<b>V</b>	<b>W</b>	<b>PE</b>

Figure 2-31 Power terminal of size G

Table 2-9 Power terminal functions of size G

<b>Terminals</b>	<b>Function</b>
L1, L2, L3	AC power supply
+DC, +DC1	For DC reactor
BR	Brake resistor, the other side of the resistor is connected to +DC
-DC	Negative DC bus
U, V, W	Output terminals (Motor terminals)
PE	Protective earth terminal

◆ Models of size J: HD700-xxT16000E~HD700-xxT20000E

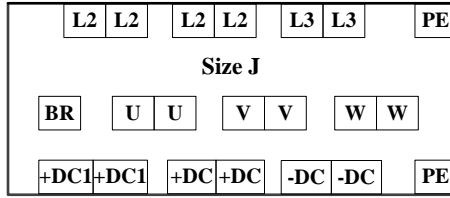

Figure 2- 32 Power terminal of size J

Table 2- 1 Power terminal functions of size J

Terminals	Function
L1, L2, L3	AC power supply
+DC, +DC1	For DC reactor
BR	Brake resistor, the other side of the resistor is connected to +DC
-DC	Negative DC bus
U, V, W	Output terminals (Motor terminals)
PE	Protective earth terminal

◆ Models of size K: HD700-xxT16000~HD700-xxT28000

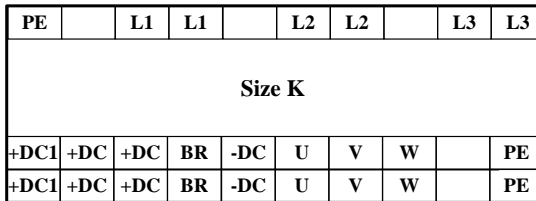

Figure 2-33 Power terminal of size K

Table 2-11 Power terminal functions of size K

Terminals	Function
L1, L2, L3	AC power supply
+DC, +DC1	DC reactor terminals
BR	Brake resistor, the other side of the resistor is connected to +DC
-DC	Negative DC bus
U, V, W	Output terminals (Motor terminals)
PE	Protective earth terminal

- ◆ Models of size K1: HD700-xxT31500E、HD700-xxT35500E

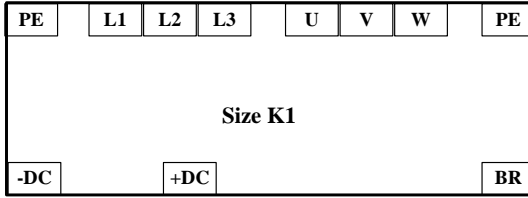

Figure 2- 34 Power terminal of size K1

Table 2- 12 Power terminal functions of size K1

Terminals	Function
L1, L2, L3	AC power supply
+DC	Positive DC bus
BR	Brake resistor, the other side of the resistor is connected to +DC
-DC	Negative DC bus
U, V, W	Output terminals (Motor terminals)
PE	Protective earth terminal

- ◆ Models of size L: HD700-xxT31500~HD700-xxT45000

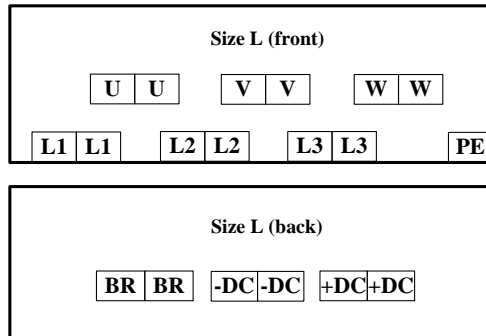

Figure 2- 35 Power terminal of size L



Table 2- 13 Power terminal functions of size L

Terminals	Function
L1, L2, L3	AC power supply
+DC	Positive DC bus
BR	Brake resistor, another end is +DC
-DC	Negative DC bus
U, V, W	Output terminals (Motor terminals)
PE	Protective earth terminal

NOTE: In “HD700-××T”, the first “×” means 4 or 6 and the second “×” means 0 or 1.

### 2.3.2 Power connections

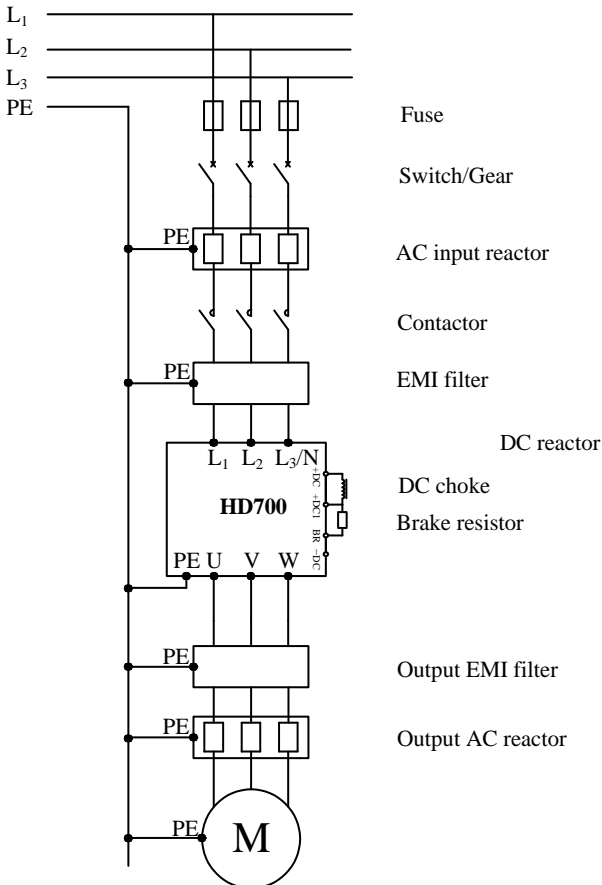

Figure 2-36 Typical power connection

## NOTE:

- To know how to choose fuse and switch please refer to table 2-14.
- When the contactor is used in power supply control ,it is not suggested to use the power contactor to control the drive to RUN/STOP .
- Under default carrier frequency, the maximum motor cable length is 100 meters. When the motor cable is longer than 100m, output reactor is suggested to use.
- For the sake of safety, the drive and motor must be earthed, and the earth resistance must be less than 10Ω, and the cross-sectional area of earth conductor must meet the requirements in table 2-15.

Table 2-14 Recommended fuse, power cable and control cable

Model	Fuse				Power				Control cable (mm <sup>2</sup> )
	IEC gG (A)		<30A, CC class >30A, T class (A)		Input current (A)	Supply cable (mm <sup>2</sup> )		Motor cable (mm <sup>2</sup> )	
	1PH	3PH	1PH	3PH	1/3PH	1PH	3PH	3PH	
HD700-20D00040	10	8	10	8	7.1/4	1.5	1.0	1.0	≥0.5
HD700-20D00075	16	10	15	10	12.8/7.1	2.5	1.0	1.0	≥0.5
HD700-20D00150	25	16	25	15	20.5/11.3	2.5	1.5	1.0	≥0.5
HD700-20D00220	32	20	32	20	24/14.5	4.0	2.5	1.5	≥0.5
HD700-20D00400	20		20		16.5	2.5		2.5	≥0.5
HD700-40T00075	8		8		3.6	1.0		1.0	≥0.5
HD700-40T00150	10		10		5.7	1.0		1.0	≥0.5
HD700-40T00220E	16		15		8.3	1.5		1.0	≥0.5
HD700-40T00220	16		15		8.3	1.5		1.0	≥0.5
HD700-40T00400	20		20		13.2	2.5		1.5	≥0.5
HD700-40T00550E	32		20		14.3	2.5		2.5	≥0.5
HD700-40T00550P	32		20		14.3	2.5		2.5	≥0.5
HD700-40T00550	20		20		12.4	2.5		2.5	≥0.5
HD700-40T00750	25		25		16.1	2.5		2.5	≥0.5
HD700-40T01100P	40		40		21	4.0		4.0	≥0.5
HD700-40T01100	40		40		31	4.0		4.0	≥0.5
HD700-40T01500	50		45		36	6.0		6.0	≥0.5
HD700-40T01850	63		60		44	10		10	≥0.5

Model	Fuse		Power			Control cable (mm <sup>2</sup> )
	IEC gR (A)	Ferraz HSJ (A)	Input current (A)	Supply cable (mm <sup>2</sup> )	Motor cable (mm <sup>2</sup> )	
HD700-40T02200	80	80	58	16	16	≥0.5
HD700-40T03000E	110	110	72	25	25	≥0.5
HD700-40T03700E	125	125	93	25	25	≥0.5
HD700-40T03000	110	110	72	25	25	≥0.5
HD700-40T03700	125	125	93	25	25	≥0.5
HD700-40T04500	200	175	121	35	35	≥0.5
HD700-40T05500	250	225	151	70	70	≥0.5
HD700-40T07500	250	225	175	95	95	≥0.5
HD700-40T09000	250	250	204	120	120	≥0.5
HD700-40T11000	315	300	248	150	150	≥0.5
HD700-40T13200	350	400	301	185	185	≥0.5
HD700-40T16000E	450	500	340	120×2	120×2	≥0.5
HD700-40T18500E	500	500	375	120×2	120×2	≥0.5
HD700-40T20000E	500	500	415	120×2	120×2	≥0.5
HD700-40T16000	450	500	340	120×2	120×2	≥0.5
HD700-40T18500	500	500	375	120×2	120×2	≥0.5
HD700-40T20000	630	600	457	120×2	120×2	≥0.5
HD700-40T25000	670	–	505	150×2	150×2	≥0.5
HD700-40T28000	700	–	592	150×2	150×2	≥0.5
HD700-40T31500	700	–	653	150×3	150×3	≥0.5
HD700-40T35500	1000	–	728	150×4	150×4	≥0.5
HD700-40T31500E	700	–	653	150×3	150×3	≥0.5
HD700-40T35500E	1000	–	728	150×4	150×4	≥0.5
HD700-40T40000	1000	–	810	150×4	150×4	≥0.5
HD700-40T45000	1000	–	915	150×4	150×4	≥0.5
HD700-60T03000	63	60	42	10	10	≥0.5
HD700-60T03700	80	60	52	16	16	≥0.5
HD700-60T04500	100	90	61	16	16	≥0.5
HD700-60T05500	125	100	83	25	25	≥0.5
HD700-60T07500	125	125	97	35	35	≥0.5
HD700-60T09000	200	175	127	50	50	≥0.5
HD700-60T11000	250	225	145	70	70	≥0.5
HD700-60T13200	250	225	145	70	70	≥0.5
HD700-60T16000E	250	225	170	50×2	50×2	≥0.5
HD700-60T18500E	250	250	192	50×2	50×2	≥0.5
HD700-60T20000E	315	300	224	70×2	70×2	≥0.5

Model	Fuse		Power			Control cable (mm <sup>2</sup> )
	IEC gR (A)	Ferraz HSI (A)	Input current (A)	Supply cable (mm <sup>2</sup> )	Motor cable (mm <sup>2</sup> )	
HD700-60T16000	250	250	192	50×2	50×2	≥0.5
HD700-60T18500	315	300	224	50×2	50×2	≥0.5
HD700-60T20000	350	350	266	70×2	70×2	≥0.5
HD700-60T25000	350	400	285	90×2	90×2	≥0.5
HD700-60T28000	350	400	318	120×2	120×2	≥0.5
HD700-60T31500	500	500	375	120×2	120×2	≥0.5
HD700-60T35500	500	500	413	120×2	120×2	≥0.5
HD700-60T31500E	500	500	375	120×2	120×2	≥0.5
HD700-60T35500E	500	500	413	120×2	120×2	≥0.5
HD700-60T40000	630	600	468	120×2	120×2	≥0.5
HD700-60T45000	670	–	529	150×2	150×2	≥0.5

Table 2-15 Earth conductor cross sectional area

Power cable cross sectional area-S (mm <sup>2</sup> )	Earth conductor cross sectional area-Sp (mm <sup>2</sup> )
S≤16	S
16<S≤35	16
35<S	S/2

NOTE: The data in the table 2-12 is based on the fact that - two conductors are made of the same metal material; otherwise the - value should be modified by the conductor factor between - different metal materials.

### 2.3.3 Typical cabling

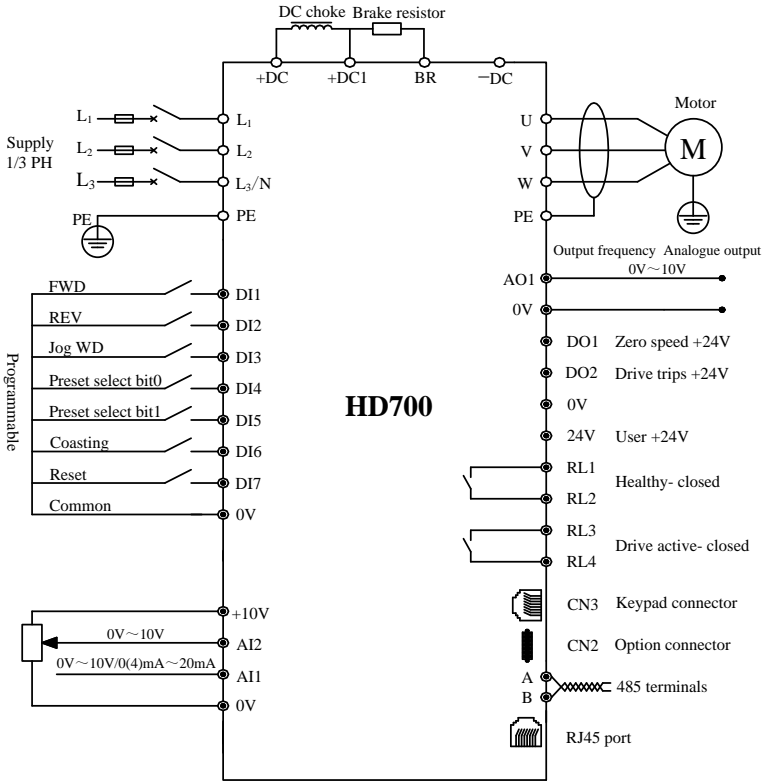

Figure 2-37 Typical cabling

**NOTE:**

- All the programmable control terminal functions are - defaults -.
- For control wire, - unshielded twisted pair, shielded cable or shielded twisted pair are recommended.
- 5.5kW~280kW models (including 220V/4kW, except size E1 models) have built-in - DC reactors -. 315kW~450kW models have built-in AC reactors-.

## 2.3.4 Control terminals specification

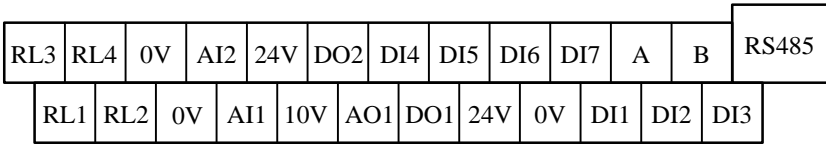

Figure 2-38 Control terminal diagram

Table 2-16 Control terminal and comms. port

Type	Terminal Name	Function	Technical Specification-
Serial comms.	RS485	RJ45 port	Two lines, Modbus RTU protocol
	A	485 plus signal	Same function with RJ45 port, mainly for multi network
	B	485 minus signal	
Digital input	DI1~DI5	Programmable digital input terminals	The common can be 0V or 24V by setting - P09.21 (default is 0V) Input resistance: 10 kΩ High, low logic threshold: 10V±1V Sampling period: 1ms
	DI6	Normal digital input Length counting Number counting	<ul style="list-style-type: none"> <li>• Same as DI1~DI5</li> <li>• Length counting by input pulse signal Sampling period: 5ms</li> <li>• Number counting by input pulse signal Sampling period: 5ms</li> </ul> Note: pulse frequency range is 0Hz~60Hz.
	DI7	Normal digital input High frequency pulse input Motor thermister input	<ul style="list-style-type: none"> <li>• Same as DI1~DI5, but Input resistance is 5kΩ</li> <li>• High frequency pulse input Frequency range: 1kHz~50kHz</li> <li>• Only when P09.21=1 can it be thermister input -motor overheating protection resistance: 3kΩ Reset resistance: 1.8kΩ Sampling period: 5ms</li> </ul>

Type	Terminal Name	Function	Technical Specification-
<b>Digital output</b>	DO1	Programmable digital output terminal 1	Output: 24V/0V Max. output current: 50mA Updating rate: 20ms
	DO2	Programmable digital output terminal 2	<ul style="list-style-type: none"> <li>● same with DO1</li> <li>● High frequency pulse output (0.1kHz to 50kHz)</li> <li>● PWM output (10kHz)</li> </ul>
<b>Analogue input and output</b>	AI1	Programmable analogue input 1	0V~10V Input resistance: 100kΩ 0 (4) mA~20mA Load resistance:188Ω Min. Potentiometer resistance: 0.5kΩ Resolution: 0.1% Accuracy: 2% Sampling period: 5ms
	AI2	Programmable analogue input 2	0V~10V Input resistance: 30kΩ Min. Potentiometer resistance: 0.5kΩ Resolution: 0.1% Accuracy: 2% Sampling period: 5ms
	AO1	Programmable analogue output	0V~10V Max. output current: 5mA Resolution: 0.4% Accuracy: ±5% Updating rate: 5ms
<b>Rail supply and Relay</b>	10V	Analogue reference supply	Accuracy: 2% Max. output current: 20mA
	24V	User supply (2)	Accuracy: ±15% Maximum output current: 100mA
	0V	Common (3)	Common reference point for control signal

Type	Terminal Name	Function	Technical Specification-
Rail supply and Relay	RL1, RL2	Programmable relay1 output contacts	Type: normally open Updating rate: 5ms
	RL3, RL4	Programmable relay2 output contacts	Contactor rating: 250VAC/2A(cosφ=1) 250VAC/1A(cosφ=0.4) 30VDC/1A Default: Relay1: closed when powered and healthy. Relay2: closed when drive is active.

- Digital input terminal basic function

There are 7 programmable digital input terminals.

P09.01=0 (default), only basic function for digital input

P09.01=1, advanced functions are available for digital input.

This manual only introduces the basic function of digital input.

The basic function list is as the following table:

Table 2-17 HD700 digital input basic function list

Terminal	Parameter	Range	Default
DI1	P09.02	0: Preset select bit 0 1: Preset select bit 1	3
DI2	P09.03	2: Run 3: Run forward 4: Run reverse	4
DI3	P09.04	5: 3-wire enable 6: FWD/REV 7: Jog forward	7
DI4	P09.05	8: E Pot (UP) 9: E Pot (DOWN)	0
DI5	P09.06	10: Enable 11: Reset 12: Switch to terminal control	1
DI6	P09.07	13: Reset of length counting 16: Preset select bit2 17: Preset select bit3	10
DI7	P09.08	18: PLC reset indicator 19: No function 99: Advanced function	11



- Digital input

The common port of DI could be programmed as 0V or 24V, the default is 0V. The parameter P09.21 can control the selection. When

P09.21=0, common is 0V

P09.21=1, common is 24V.

Different connection types of DI and common are as showed in table 2-17.

Table 2-18 Digital input connection examples

P09.21 Connection		P09.21=0 (Source)	P09.21=1 (Sink)
Switch type	By inner 24V		
	By outer supply	-	

P09.21		P09.21=0 (Source)	P09.21=1 (Sink)
Connection			
OC (NPN)	By inner 24V		
	By Outer supply		
OC (PNP)	By inner 24V		
	By Outer supply		

NOTE: When outer power supply is used, the range is: 11V~30V.

When DI7 is set as motor thermistor input, the connection is shown as figure 2-34.

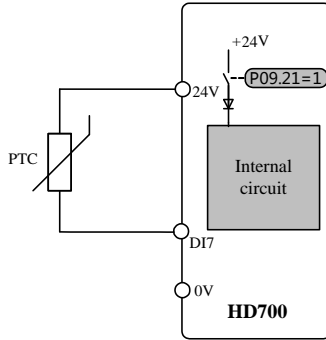

Figure 2-39 PTC thermistor connection

- Digital output

There are 2 digital output terminals, all OC type (24V output). DO2 can be set as high frequency pulse output; when using the DO to drive relay, please take care of the polarity of the relay winding, and add the snubber circuit to the winding.

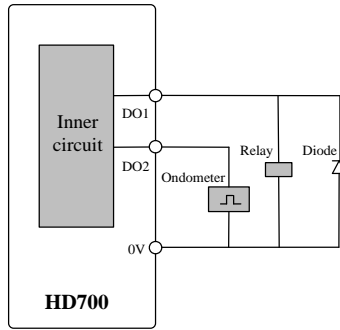

Figure 2-40 Digital output connection

- Analogue input

HD700 drive has two Analogue input channels.

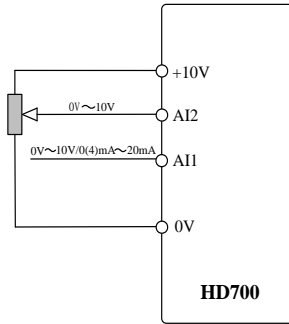

Figure 2-41 Analogue input connection

- Analogue output

Output is voltage (0V ~ 10V), maximum output current is 5mA.

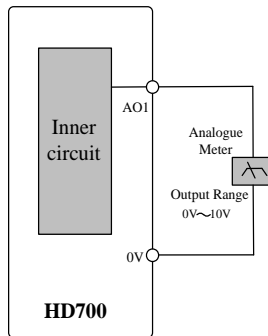

Figure 2-42 Analogue output connection

### 2.3.5 Brake resistor

The choice of brake resistor in specific application is decided by motor power, system inertia, deceleration rate, etc. For how to design the brake resistor, please refer to the **HD700 Technical Data Manual**.

Table 2-19 220V supply voltage brake resistor specification

Model	Spec.	Min. resistance (Ω)	Max. brake current (A)	Peak power (kW)	Recommended resistance (Ω)
HD700-20D00040		41	10	4.15	82
HD700-20D00075		41	10	4.15	82
HD700-20D00150		41	10	4.15	82
HD700-20D00220		20	21	8.48	40
HD700-20D00400		12	35	14.3	24

Table 2-20 380V supply voltage brake resistor specification

Model	Spec.	Min. resistance (Ω)	Max. brake current (A)	Peak power (kW)	Recommended resistance (Ω)
HD700-40T00075		120	7	5.67	240
HD700-40T00150		120	7	5.67	240
HD700-40T00220E		120	10	5.67	240
HD700-40T00220		65	13	10.4	130
HD700-40T00400		50	17	13.5	100
HD700-40T00550E		24	35	28.7	48
HD700-40T00550P		50	17	13.5	100
HD700-40T00550		24	35	28.7	48
HD700-40T00750		24	35	28.7	48
HD700-40T01100P		24	35	28.7	48
HD700-40T01100		24	35	28	48
HD700-40T01500		17	50	40	34
HD700-40T01850		17	50	40	34
HD700-40T02200		17	50	40	34
HD700-40T03000E		11	75.5	55.3	22
HD700-40T03700E		11	75.5	55.3	22
HD700-40T03000		11	75.5	55.3	22
HD700-40T03700		11	75.5	55.3	22
HD700-40T04500		9	92	67.6	18
HD700-40T05500		7	120	86.9	14
HD700-40T07500		7	120	86.9	14
HD700-40T09000		4.2	200	164	8.4
HD700-40T11000		2.8	300	246	5.6

Model	Spec.	Min. resistance (Ω)	Max. brake current (A)	Peak power (kW)	Recommended resistance (Ω)
HD700-40T13200		2.8	300	246	5.6
HD700-40T16000E		1.8	450	357	3.6
HD700-40T18500E		1.8	450	357	3.6
HD700-40T20000E		1.8	450	357	3.6
HD700-40T16000		1.8	450	357	3.6
HD700-40T18500		1.8	450	357	3.6
HD700-40T20000		1.8	450	357	3.6
HD700-40T25000		1.4	600	493	2.8
HD700-40T28000		1.4	600	493	2.8
HD700-40T31500		0.9	900	765	1.8
HD700-40T35500		0.9	900	765	1.8
HD700-40T31500E		0.9	900	765	1.8
HD700-40T35500E		0.9	900	765	1.8
HD700-40T40000		0.7	1200	984	1.4
HD700-40T45000		0.7	1200	984	1.4

Table 2-21 690V supply voltage brake resistor specification

Model	Spec.	Min. resistance (Ω)	Max. brake current (A)	Peak power (kW)	Recommended resistance (Ω)
HD700-60T03000		13	92	95	26
HD700-60T03700		13	92	95	26
HD700-60T04500		13	92	95	26
HD700-60T05500		10	119	125.5	20
HD700-60T07500		10	119	125.5	20
HD700-60T09000		8	150	177	16
HD700-60T11000		8	150	177	16
HD700-60T13200		5.3	225	267	10.6
HD700-60T16000E		5.3	225	267	10.6
HD700-60T18500E		5.3	225	267	10.6
HD700-60T20000E		4	300	353	8
HD700-60T16000		5.3	225	267	10.6
HD700-60T18500		5.3	225	267	10.6
HD700-60T20000		4	300	353	8
HD700-60T25000		4	300	353	8
HD700-60T28000		2.7	450	535	5.4
HD700-60T31500		2.7	450	255	5.4
HD700-60T35500		2	600	344	4
HD700-60T31500E		2.7	450	255	5.4
HD700-60T35500E		2	600	344	4

Model \ Spec.	Min. resistance (Ω)	Max. brake current (A)	Peak power (kW)	Recommended resistance (Ω)
HD700-60T40000	2	600	344	4
HD700-60T45000	1.3	900	530	2.6

### 2.3.6 EMC Guide

EMC suggestions:

- Immunity
 

360 degree ground clamps should be used to connect the screen of the cable; avoid "Pigtail" ground fitting.

Control cable and power cable should be laid out in independent metal grooves; the earth conductor in the motor cable must be connected directly to the earth terminal of the drive and the motor. - Shielded motor cable is recommended.
- Cable clearance
 

Don't place control cable in a zone extending 300mm around the drive and power cables.

### 2.3.7 EMC Filter

- Optional RFI filter
  - Place the RFI filter to the drive as close as possible, and the shorter the cable between the filter and drive is-, the better.
  - The metal enclosure of the filter must be connected with the drive earth terminal.
- Internal EMC filter
 

The drive leakage current is different when with internal EMC filter and when without.

Table 2-22 HD700 ground leakage current data

Model	Supply voltage	With internal EMC filter (mA)	Without internal EMC filter (mA)
Size A	200V	10	0.1
	400V	9	0.1
Size B	200V	11	0.1
	400V	7	0.1
Size C	200V	8	0.0
	400V	18	0.3
Size D	400V	17	0.1
Size E	400V	18	0.1
Size E1	400V	8	0.1
Size F	400V	20	2.4
	690V	29	6.7

Model	Supply voltage	With internal EMC filter (mA)	Without internal EMC filter (mA)
Size G	400V	22	2.6
	690V	30	6.9
Size J	400V	24	0.4
	690V	12	0.8
Size K	400V	63	3.1
	690V	77	7.2
Size K1	400V	9.2	1.0
	690V	15.9	1.7
Size L	400V	9.2	1.0
	690V	15.9	1.7

NOTE:

- The test condition of the table 2-21 is without motor load.
  - When a ground leakage protecting contactor is used for front power supply, the internal EMC filter should be removed.
- Fit and remove the internal EMC filter

There is a metal link between the ground and EMC filter as shown in the below figures.

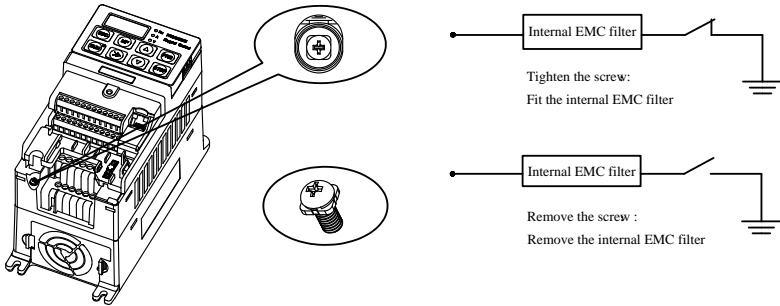

Figure 2-43 Fit and remove the internal EMC filter (Size A)

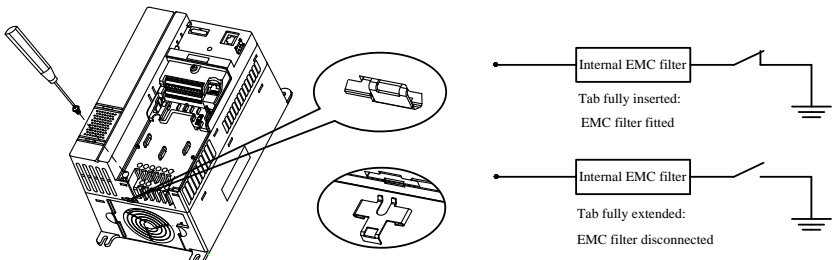

Figure 2-44 Fit and remove the internal EMC filter (Size B, C)



NOTE: After removing the link of EMC filter, please keep the link in case to fit the EMC filter again.

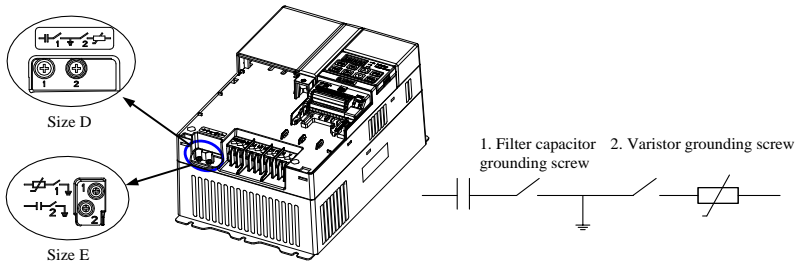

Figure 2-45 Fit and remove the internal EMC filter (Size D, E)

Tighten the filter capacitor grounding screw, and fit the internal EMC filter.

Untighten the filter capacitor grounding screw, and disconnect the internalc EMC filter.

NOTE: When disconnecting varistor, please twist out and remove the screw.

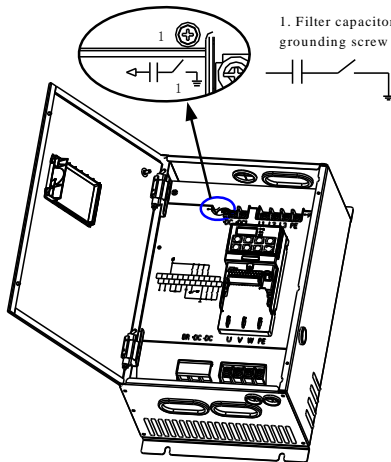

Figure 2-46 Fit and remove the internal EMC filter (Size E1)

Tighten the filter capacitor grounding screw, and fit the internal EMC filter.

Untighten the filter capacitor grounding screw, and disconnect the internalc EMC filter.

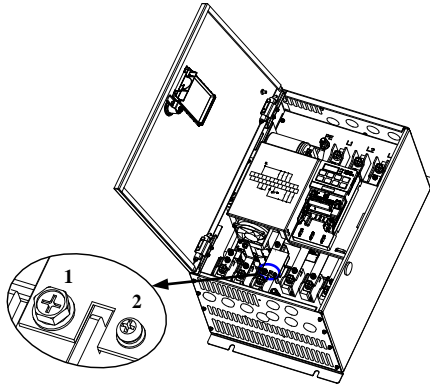

Figure 2-47 Fit and remove the internal EMC filter (Size F)

Untighten screws 1, 2 and remove the EMC filter board, and then remove the EMC filter.

NOTE: In order to ensure reliable earthing, please tighten the screws 1, 2 after removing the EMC filter.

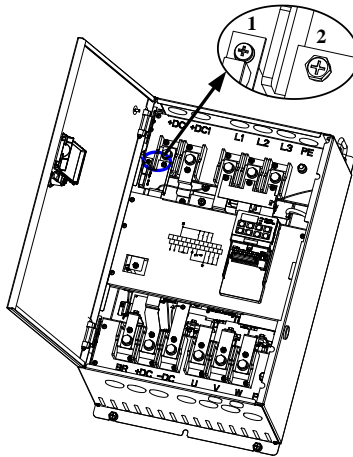

Figure 2-48 Fit and remove the internal EMC filter (Size G)

Untighten screws 1, 2 and remove the EMC filter board, and then remove the EMC filter.

NOTE: In order to ensure reliable earthing, please tighten the screws 1, 2 after removing the EMC filter.

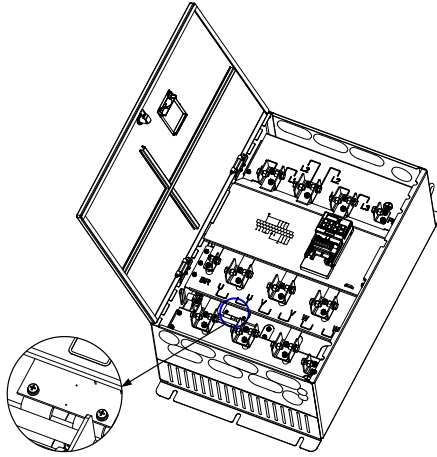

Figure 2-49 Fit and remove the internal EMC filter (Size J)

Untighten screws and remove the EMC filter board, and then remove the EMC filter.

NOTE: In order to ensure reliable earthing, please tighten the screws after removing the EMC filter.

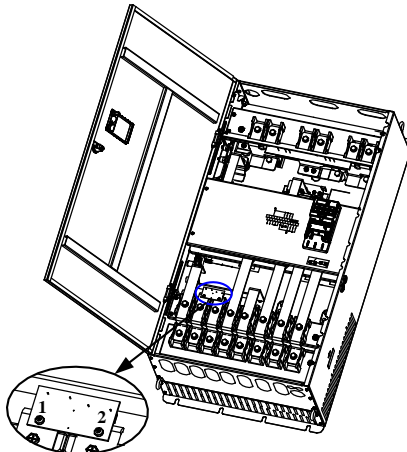

Figure 2-50 Fit and remove the internal EMC filter (Size K)

Untighten screws 1, 2 and remove the EMC filter board, and then remove the EMC filter.

NOTE: In order to ensure reliable earthing, please tighten the screws 1, 2 after removing the EMC filter.

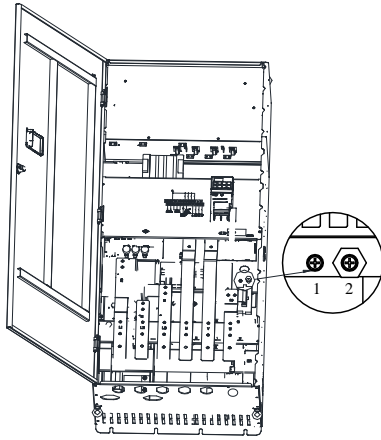

Figure 2-51 Fit and remove the internal EMC filter (Size K1)

If you want to remove the EMC filter, please make screw 1 unscrewed and disconnect wiring. Wiring to - screw 2 is suggested, to avoid- the EMC wiring contacting - other parts of the drive.

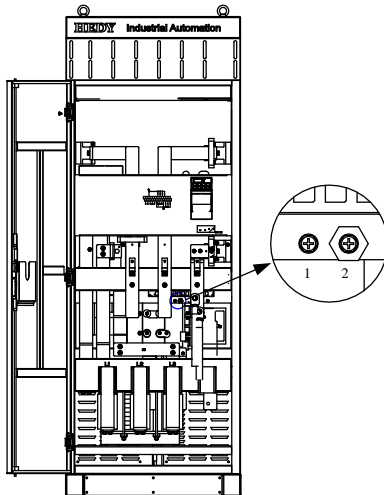

Figure 2-52 Fit and remove the internal EMC filter (Size L)

If you want to remove the EMC filter, please make screw 1 unscrewed and disconnect wiring. Wiring to screw 2 is suggested, to avoid the EMC wiring contacting other parts of the drive.

## 3 Operation and display

### 3.1 Keypad

There are a 5-digit LED display of 8 segment, 3 - lights, and a RUN light on the HD700 drive keypad as shown below:



Figure 3-1 LED keypad

#### 3.1.1 LED lights









LED display can show the drive status, parameters and value, fault, warning information, etc. Run light is on the upper right corner of the key of , when drive is active, the light is on.

Table 3-1 LED lights

Unit	Function	Colour
Hz	On: output frequency Flashing: Reference frequency	Green
A	On: Output current	Green
V	On: Output voltage (RMS) Flashing: DC bus voltage	Green

### 3.1.2 Key function

Table 3-2 key function

key	Function Description
	-Pressing the key will return to the previous level; long pressing the key will display the value of - parameter decided by P05.01. When the keypad is locked, pressing and holding the key for 5 seconds will unlock.
	Programmable key, - can be functioned as Jog, Fwd./Rev., - and stop by setting P05.07. Default function is Jog.
	Enter next level of the keypad display.
	When in keypad control mode (P00.03 or P10.07=0), pressing this key will make the drive run.
	<ul style="list-style-type: none"> <li>• Stop, the switch will stop the drive unless the keypad is locked totally.</li> <li>• Reset the drive if the keypad is not locked totally.</li> </ul>
	Are used to select parameters and edit their values. In keypad mode, they are used to increase and decrease the speed of the motor.
	<ul style="list-style-type: none"> <li>• Under Run/Stop mode, pressing this key - will change output frequency, reference frequency, output current, output voltage, DC bus voltage in turn</li> <li>• Under editing parameter value mode, pressing this key will move the flashing digit to the left.</li> </ul>

NOTE: If there is a conflict in the content of parameter, pressing “PRG” key will not enter the next parameter.

### 3.1.3 Keypad operation

Keypad can control the operation of the drive, or monitor the status of the drive, details as below:

- LED Display

- If P05.02 is set to 0

Normal display is the value of the parameter which is selected by the P05.01; default is output frequency (value of P05.11).

HD700 has a quick display group, -and parameters of output frequency, reference frequency, output current, output voltage, and DC bus voltage are displayed in turn.

Operation procedure is as figure 3-2:

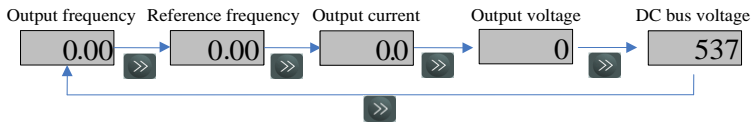

Figure 3-2 Display switchover flow

- If P05.02 is set to 1

In standby mode, normal display is reference frequency. Operation procedure is as figure 3-3:

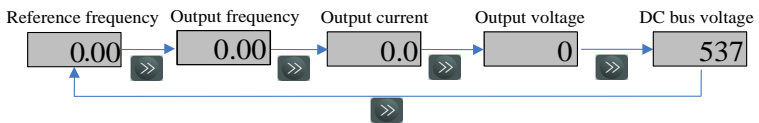

Figure 3-3 Display switchover flow

In running mode, normal display is output frequency. Operation procedure is as figure 3-4:

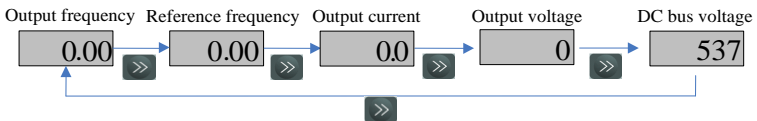

Figure 3-4 Display switchover flow

NOTE:

- ✧ Normal display can be the value of any parameter selected by P05.01. For example, if setting P05.01=5.08, then the normal LED display will be motor speed.
- ✧ During the display cycle-, pressing the - ESC key, and the LED display will return to the normal display content.

- How to - view and edit parameters -

For HD700 family, there are three levels of menu to view and edit parameters.

Level 1: menu group

Level 2: parameter

Level 3: parameter content

Operation flow is described in figure 3-5:

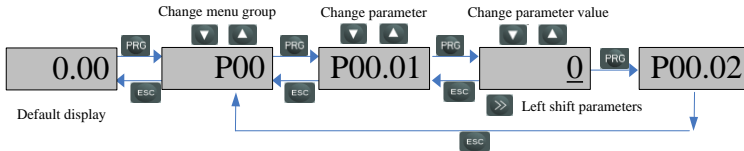

Figure 3-5 parameter view and edit flow

NOTE:

- ✧ In level 3, user can turn to level 2 by pressing the PRG button or the ESC button, and the difference is:
  - Pressing PRG will save the change of the value and return to level 2 (next parameter), pressing PRG again will display the value of next parameter.
  - Pressing ESC will not save the change and will return to level 2 (current parameter), pressing ESC again will return to level 1.
- ✧ Only after pressing PRG can the change of parameter value - be effective.
- ✧ If there's no digit flashing for a parameter value -, it means the value of the parameter can not be changed, the reasons maybe:
  - It is an actual parameter, can not be changed
  - Drive is running, and the parameter can not be changed in running mode
- ✧ If more than one parameter are set to same value (function), the following will happen :
  - When setting up with keypad, the change will not be effective after pressing PRG, and the display can not enter the next parameter
  - When setting up with PCTools, the drive will trip at F021

Table 3-3 List of parameters with conflict setup

Analogue input	Digit input	PID output source	Logic output source	Threshold and selector output source
P08.03, P08.08	P09.02~P09.08	P15.15	P16.07, P16.14, P16.19	P17.05, P17.10, P17.17, P17.24, P17.31

For example:



The default function of digit input terminal are:

P09.02=3 DI1 function is Run forward.

P09.03=4 DI2 function is Run reverse.

If changing the setup of DI2, like setting P09.03=3 (DI2 function is forward running also), pressing PRG, and the value of P09.03 is still "4", and the Display can not enter the next parameter P09.04.

- Example of editing parameter

The example is to change the value of P04.01 from 5.00Hz to 40.50Hz, as the following figure 3-6. The digit with an underline is flashing.

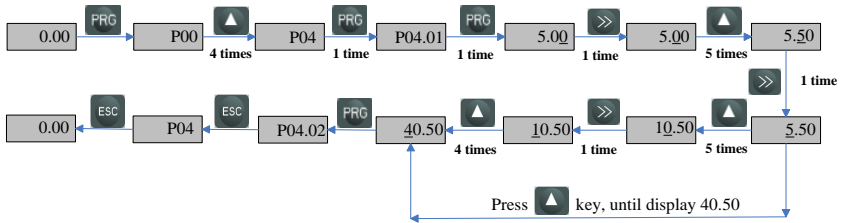

Figure 3-6 Editing parameter flow

- Lock and unlock the keypad

To avoid wrong keypad operation, HD700 has the function of keypad locking by setting P05.06, if the value of P05.06 is:

0: all the keys are available

1: all the keys are locked

2: except RUN and STOP keys, other keys are locked.

Keypad unlocking operation: pressing and holding ESC for 5 seconds and the value of P05.06 will become "0", and the keypad is unlocked.

- User code

To protect parameters set up by user, HD700 has the function of user code. Once the user code is set, if user can not enter the correct PIN for P00.01, the keypad can only display normal display and parameter P10.06, and its value is "0".

- Set the user code

Default value of P00.01 is "0", and user code function is disabled. If setting P10.06 a non-zero value (1~9999), pressing PRG once and pressing ESC twice, the user code function will be activated. The example of setting the user code to 4 is showed as below figure 3-7:

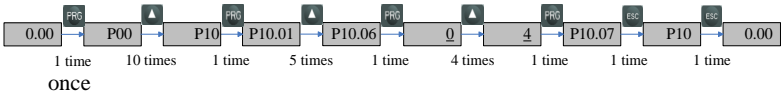

Figure 3-7 User code setting flow

- Verify the user code (PIN)

When the user code is set, only after entering the correct PIN into P10.06 and pressing PRG, can user view and edit all the parameters. After verifying user code successfully, if there's no action on any key - in two minutes, the value of P10.06 will be changed to "0" automatically, the user code function is effective, and the keypad will show the normal display (selected by P05.01).

If the PIN is "8", and the user code function is as on Enable stage, following figure 3-8 shows how to pass the PIN verifying.

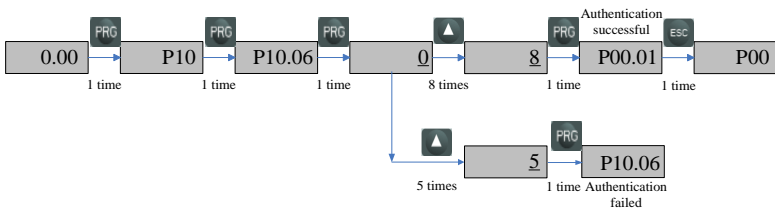

Figure 3-8 PIN verifying procedure



- Remove the user code

There are two methods to remove the user code:

- Software remove

After verifying the PIN successfully, change the value of P10.06 to "0", then press PRG, and the user code will be removed.

- Hardware remove

When the drive is power-off, press the keys of  +  +  at the same time, then loosen the keys after powering up. Then change the value of P10.06 to "0", and - the user code can be removed.

- Autotune

When do the motor auto-tune, make sure to set up the correct data of motor from the motor nameplate.

Refer to the motor nameplate; enter right value into following parameters:

P00.13 (P13.06)	motor rated voltage
P00.14 (P13.07)	motor rated current
P00.15 (P13.08)	motor rated frequency
P00.16 (P13.10)	motor rated speed (RPM)
P00.19 (P13.05)	motor power factor

Then operate as below:

Set P00.17 (P13.02) =1, press PRG, then press ESC to return the normal display, press RUN, the drive will do the autotune, and keypad display is as figure 3-9:



Figure 3-9 Autotune display

After finishing the autotune, the drive will stop and P00.17 will be "0".

## 3.2 Drive control

### 3.2.1 Drive status

HD700 drive status is defined as: Ready (Stop), Running, Editing, Auto-tune, Trip, and Alarming.

**Stop:** After powering up and resetting the drive, if there is no RUN action, - drive will keep stopping, and RUN light is off.

**Running:** The drive is activated, with RUN light on.

**Editing:** with keypad or PCTools, program the parameters.

**Autotune:** When setting P00.17 (P13.02) to "1" or "2" , and - running the drive, it will do the motor auto-tune, and keypad will display "U", RUN light will be on, and after autotune, the drive will -stop.

**Trip:** Because of internal fault, external fault or wrong operation, the drive will trip and display corresponding fault code.

**Alarm:** When drive is under alarm status, keypad will display corresponding alarm code (Hxxx). The alarm code will keep flashing for 3 seconds and then turn to the normal display

(selected by P05.01). The normal display will flash for 3 seconds then back to alarm code, and the keypad will keep this cycle until the alarm is removed. The parameter P12.13 can be set to display the alarm information or not.

### 3.2.2 Control modes

Through P00.03 (P10.07), there are 3 control modes:

- 0: Keypad
- 1: Terminal
- 2: Serial comms.

### 3.2.3 Reference source

HD700 has 9 kinds of reference sources, by setting P00.04 (P01.01), source channels are as following:

- 0: Keypad
- 1: E-Pot
- 2: Preset
- 3: AI1
- 4: AI2
- 5: Serial communication
- 6: DI7 Pulse
- 7: Field bus option
- 8: User program

### 3.2.4 Priority of running mode

Under speed mode, HD700 has 4 running modes, the priority level from high to low is as: Jog > PLC > Textile > Common running, showed in figure 3-10:

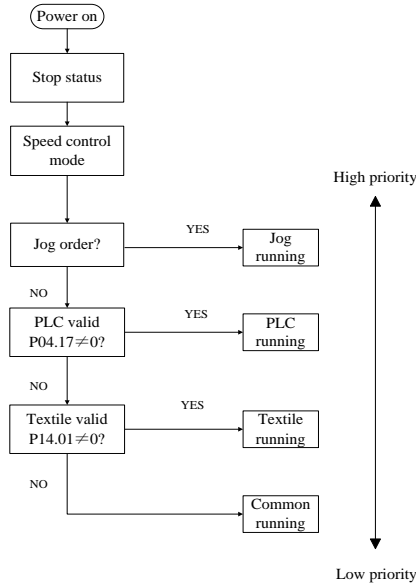

Figure 3-10 HD700 Running mode Priority

## 3.3 Quick commissioning

### 3.3.1 Keypad control

Use the parameter menu0 to explain the drive setup as below.

Table 3-4 Keypad control setup

Parameter Setup	Description
P00.13=motor nameplate data	Set the motor rated voltage
P00.14=motor nameplate data	Set the motor rated current
P00.15=motor nameplate data	Set the motor rated frequency
P00.16=motor nameplate data	Set the motor rated speed
P00.19=motor nameplate data	Set the Power factor of the motor

Other parameters are default setup.

- Jog  
Press **MF** and hold, the drive will run at 5.00Hz (default value of P01.04) at the accelerating rate (set by P02.22), release the key, the drive will stop at the ramp mode set by P03.10.  
NOTE: To jog again you have to wait for the interval period set by P02.24.
- Common run  
Press **RUN**, drive will run, with Run light on. Press **▲**, output frequency will be up, Press **▼**, output frequency will be down. Press **STOP**, the drive will stop at the ramp mode set by P03.10, then the Run light will go off.

### 3.3.2 Terminal control

Table 3-5 Terminal control setup

Parameter Setup	Description
P00.03=1	Terminal Control
P00.04=3	Reference is from AI1
P00.13=motor nameplate data	Set the motor rated voltage
P00.14=motor nameplate data	Set the motor rated current
P00.15=motor nameplate data	Set the motor rated frequency
P00.16=motor nameplate data	Set the motor rated speed
P00.19=motor nameplate data	Set the Power factor of the motor

Other parameters are default setup.

Control terminal cabling as following figure 3-11:

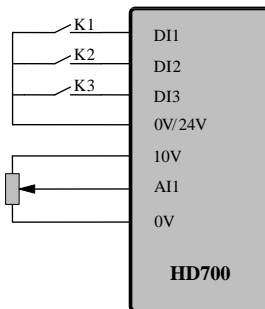

Figure 3-11 Two-wire (default) cabling

- Close switch K1, the drive will run forward and the run light will be on. Open the switch K1, the drive will stop at the ramp mode set by P03.10. When the inverter is disabled, the run light will go off.
- Close switch K2, the drive is running reverse and the run light will be on. Open the switch K2, the drive will stop at the ramp mode set by P03.10. When the inverter is

disabled, the run light will be off.

NOTE: Adjusting the potentiometer can change the output frequency.

- Close K1 and K2 at the same time, the drive will stop running.
- Close switch K3, the drive will run at 5.00Hz (default value of P01.04) at the acceleration rate (set by P02.22). Open switch K3, the drive will stop at the ramp mode set by P03.10.

NOTE: To jog again you have to wait for the interval period set by P02.24.

Parameter P09.22 is used to define the 3-wire control.

P09.22=0, 3-wire is disabled (2-wire control)

P09.22=1, 3-wire control mode 1

P09.22=2, 3-wire control mode 2

- When (P09.22=1) 3-wire control mode 1 is selected, DI1, DI2, DI3 are automatically set as below:

P09.02=5     DI1 is 3-wire enable, Voltage control (SB1 is normal closed button, when it is open, drive will stop.)

P09.03=3     DI2 is Run Forward input, Latching control

P09.04=4     DI2 is Run Reverse input, Latching control

Wiring is as below figure 3-12:

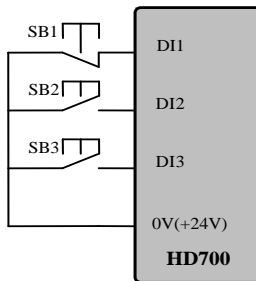

Figure 3-12 3-wire control connection

SB1: Stop button

SB2: Run Forward button

SB3: Run Reverse button

Press SB2, drive will run forward and the order is latched;

Press SB3, drive will run reverse and the order is latched;

Press SB1, drive stops.

- When (P09.22=2) 3-wire control mode 2 is selected, DI1, DI2, DI3 are automatically set as below:

P09.02=2      DI1 is "RUN" input, Latching control

P09.03=5      DI2 is 3-wire enable, Voltage control (SB1 is normal closed button, when it is open, drive will stop)

P09.04=6      DI3 is FWD/REV input, Voltage control

Wiring is as figure 3-13:

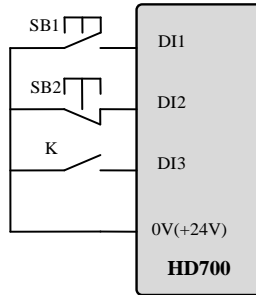

Figure 3-13 3-wire Control mode2 connection

SB1: Run button      SB2: Stop button      K: Direction switch

Press SB1, the drive will run, order is latched.

K is open, run forward; K is closed, run reverse.

Press SB2, the drive stops.

NOTE: After pressing SB2, the drive stops. Release the SB2 button and the drive still stop. You have to trigger the SB1 again to make the drive run.



## 4 Parameters

### 4.1 General description

HD700 drive's parameters are designed into two kinds, basic and advanced.

For basic application, user can set up parameter by selecting values in the basic parameter value range, like 0, 1, 2....; for advanced application, all programmable parameters can be setup in the range of advanced value range, generally P01.01 to P18.08.

In order to use the HD700 drive easily for most general purpose application, we develop a shortcut parameter group (Menu P00); summarize most popular parameters into MenuP00. In this *HD700 User manual*, we only introduce Menu P00 parameters, for total function and technical data explanation please read the *HD700 Advanced User Manual* which can be download from our website: <http://www.hedyi.com>

### 4.2 Property of parameter

The following parameter description includes:

Parameter ID: code of parameter.

Parameter name: simple explanation of the parameter.

Parameter range: the range of the parameter's value, the value in **【 】** is the default value.

Change mode: to define if the parameter can be modified, and under what condition can the parameter be changed.

Run&Stop            Write & Read can be done at running and stop state.

Stop Only            Write & Read can be done only at stop state.

Actual                Read only

### 4.3 Menu P00

In P00 parameter group, each P00.XX parameter is related with the parameter from other menus. If the P00.XX parameter is changed, the related parameter will be changed too, and vice versa. The parameters in the brackets are the related parameter codes.

Parameter ID	Parameter Name	Range 【Default】	Change Mode
P00.01 (P05.02)	Keypad cycle display mode	0~2 【1】	Run&Stop

0: Fixed mode

Keypad cycle display order: in standby or running state, the order of keypad cycle display will not be changed.

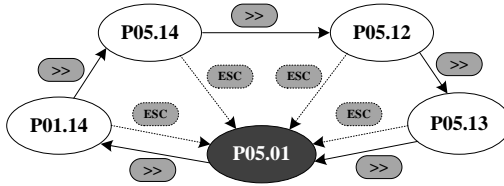

1: Auto switch mode in running state

Keypad cycle display order: the order is shown in the figure below when the drive is standby; when the drive is running, it will automatically switch to the cycle order of fixed mode.

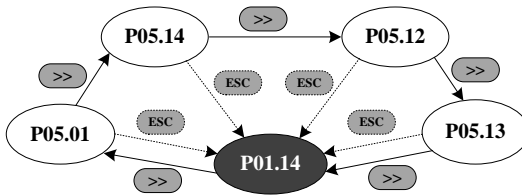

2: Reserved

Parameter ID	Parameter Name	Range 【Default】	Change Mode
P00.02 (P05.03)	Parameter display	0~2 【1】	Stop Only

0: Only parameters in menu P00

1: All parameters

2: Only parameters which have different value with the defaults

Parameter ID	Parameter Name	Range 【Default】	Change Mode
P00.03 (P10.07)	Control Mode	0~2 【0】	Stop Only

0: Keypad control

1: Terminal control

2: Serial comms. control

Parameter ID	Parameter Name	Range 【Default】	Change Mode
P00.04 (P01.01)	Reference source	0~8 【0】	Run&Stop

0: Keypad

Using the ▲ or ▼ buttons the frequency reference can be changed, and the power up frequency reference is decided by parameter P00.12 (P01.11).

1: E-Pot

Through the two terminals which are defined as UP, DOWN function the reference can be changed.

For example:

Define the DI4 and DI5 as UP and DOWN respectively, and the setup is as below:

P09.05=8 DI4 function is UP

P09.06=9 DI5 function is DOWN

2: Preset

Controlled by the digit input terminals, the frequency reference is the value of P04.01 (preset 1) ~P04.16 (preset 16).

Use the default setup as an example:

P09.05=0 DI4 is preset select bit 0

P09.06=1 DI5 is preset select bit 1

There are two operation modes:

- When the reference source is preset, terminal status is as shown below:

Table 4-1 Preset and preset terminal status corresponding table 1

DI5 Status (bit 1)	DI4 Status (bit 0)	Speed
OFF	OFF	Preset 1 (P04.01)
OFF	ON	Preset 2 (P04.02)
ON	OFF	Preset 3 (P04.03)
ON	ON	Preset 4 (P04.04)

- When the reference source is not preset, terminal status is as shown below:

Table 4-2 Preset and preset terminal status corresponding table 2

DI5 Status (bit 1)	DI4 Status (bit 0)	Speed
OFF	OFF	Keep the frequency setting
OFF	ON	Preset 2 (P04.02)
ON	OFF	Preset 3 (P04.03)
ON	ON	Preset 4 (P04.04)

About 16 presets (P04.01 ~ P04.16) control, please refer to Menu P04.

### 3: AI1

There are two analogue input terminals: AI1, AI2.

In this User manual, only AI1 is introduced.

According to parameter P08.03, AI1 has three functions:

P08.03=0, AI1 is speed reference

P08.03=1, AI1 is the speed limit under Torque control mode

P08.03=2, AI1 is the Torque error

About AI1 signal mode, there are current mode and voltage mode, for details please refer to the explanation of parameter P00.05 (P08.02).

### 4: AI2

AI2 function is decided by the parameter P08.08, it is same with AI1, and the default function is frequency reference.

AI2 can only be set to voltage mode.

For AI2 detailed setup please refer to Menu P08

### 5: Serial comms.

Under this mode, user can change the value of P04.01 (Preset 1) for the reference. For details please refer to the appendix1.

### 6: DI7 Pulse input

When P09.24=2, DI7 function is input of reference channel (by input pulse)

For example:

The maximum frequency of input pulse (P09.27) is 20.0 kHz, and actual input pulse is 10.0 kHz.

The percentage of DI7 pulse input (P09.38) is 50.0%. Then the reference is:

Reference = DI7 input percentage (P09.38) × maximum reference (P00.07)

= 50.0% × 50.00Hz

= 25.00Hz

7: Optional card (By option modules)

8: User programmed

By **destination** and source control, user can define the reference channel freely. For example through Menu P17, user can define the reference source. About actual application guide, please refer to the *HD700 Advanced User Manual*.

Parameter ID	Parameter Name	Range 【Default】	Change Mode
P00.05 (P08.02)	AI1 mode	0~6 【6】	Stop Only

AI1 signal can be voltage or current mode.

0: 0mA~20mA

1: 20mA~0mA

2: 4mA~20mA (current loosing with trip)

3: 20mA~4mA (current loosing with trip)

4: 4 mA~20mA (current loosing without trip)

5: 20mA~4mA (current loosing without trip)

6: 0V~10V

When the AI mode selection is “0~5”, if the input current is over 26mA, the drive will trip at F012, the drive will stop as the mode decided by P03.10, then turn off the IGBTs.

When this parameter is set to 2 or 3, if the input current is less than 3mA, then the drive will trip at F013, the drive will stop in the mode decided by P03.10, then turn off the IGBTs.

NOTE: If the selection is "2~5", once the current is less than 3mA, P08.16 (current loosing indicator) is 1.

Parameter ID	Parameter Name	Range 【Default】	Change Mode
P00.06 (P04.01)	Preset 1	±Max. reference 【5.00】	Run&Stop

Parameter ID	Parameter Name	Range 【Default】	Change Mode
P00.07 (P01.02)	Max. reference	0.00Hz~300.0Hz 【50.00】	Stop Only
P00.08 (P01.03)	Min. reference	0.00Hz~max. reference 【0.00】	Stop Only

If P03.01=0 (reverse is enabled), then the P00.08 is fixed at 0.00Hz.

Parameter ID	Parameter Name	Range <b>【Default】</b>	Change Mode
P00.09 (P02.04)	Acceleration rate 1	0.0s~3600.0s <b>【10.0】</b>	Run&Stop
P00.10 (P02.05)	Deceleration rate 1	0.0s~3600.0s <b>【20.0】</b>	Run&Stop

Acceleration rate is the time from 0Hz to maximum reference.

Deceleration rate is the time from maximum reference to 0Hz.

For example:

P00.07 (P01.02) = 100.00Hz, set up the maximum reference

P00.09 (P02.04) = 10.0s

After starting, the drive output frequency will ramp from 0.00Hz to 50.00Hz and the acceleration rate is:  $10.0s \times (50.00Hz/100.00Hz) = 5.0s$

Parameter ID	Parameter Name	Range <b>【Default】</b>	Change Mode
P00.11 (P03.10)	Stop mode	0~3 <b>【0】</b>	Stop Only

0: Ramp stop

1: Coasting

2: Ramp stop +DC injection

3: Coasting +DC injection

Parameter ID	Parameter Name	Range <b>【Default】</b>	Change Mode
P00.12 (P01.11)	Keypad power-up reference	0~2 <b>【0】</b>	Run&Stop

When the reference source is keypad, the reference when powered up is decided as below:

0: Starting reference is "0"

1: Starting reference is the output frequency before powered off

2: Starting reference is preset1 (P04.01)

Parameter ID	Parameter Name	Range 【Default】	Change Mode
P00.13 (P13.06)	Motor1 rated voltage	200V: 0V~240V 【220V】 400V: 0V~480V 【380V】 690V: 0V~690V 【660V】	Stop Only
P00.14 (P13.07)	Motor1 rated current	G or P type: 0.1A~rated current×1.2 GP type: 0.1A~P type rated current 【by model】	Stop Only
P00.15 (P13.08)	Motor1 rated frequency	1.00Hz~300.0Hz 【50.00】	Stop Only
P00.16 (P13.10)	Motor1 rated RPM	1rpm~60000rpm 【0】	Stop Only
P00.17 (P13.02)	Autotune selector	0~3 【0】	Stop Only

0: No action

1: Static autotune1 (first run)

When P00.17=1, press PRG to make sure the change and return to the ready stage, once there is a run order, the drive will do the static auto-tune. When finished, P00.17=0, and the drive will be in ready status.

2: Static autotune2 (every run)

When P0.17=2, every run order will be received, and the drive will do the autotune. After the static autotune, the result will be saved into the EEPROM, and P0.17=2, and the drive will be in running status.

3: Reserved

NOTE: If the auto-tune is working without load motor, the drive will trip at F016.

Parameter ID	Parameter Name	Range 【Default】	Change Mode
P00.18 (P13.11)	Motor1 stator resistance	0.000~60.000Ω 【0】	Stop Only

After auto-tune finished, this parameter will be updated. If the resistance value is out of the range, trip F016 will happen.

Parameter ID	Parameter Name	Range 【Default】	Change Mode
P00.19 (P13.05)	Motor1 power factor	0.00~1.00 【0.85】	Stop Only

PF and motor rated current (P00.14) are used to calculate the motor torque current and magnetizing current.

Parameter ID	Parameter Name	Range 【Default】	Change Mode
P00.20 (P13.01)	Motor voltage control mode	0~2 【0】	Stop Only

0: V/F control

1: Open loop vector control 1

2: Open loop vector control 2

Note: To use open loop vector control mode 1 or 2, please set up motor parameters correctly (rated voltage, current, pole pairs, rated speed) and finish auto-tune.

Parameter ID	Parameter Name	Range 【Default】	Change Mode
P00.21 (P10.10)	Switch frequency	1kHz~15kHz 【determined by model】	Run&Stop

Switch frequency can affect the motor noise and drive power loss, the higher switch frequency, the lower motor noise, but the bigger IGBT power loss.

Parameter ID	Parameter Name	Range 【Default】	Change Mode
P00.22 (P06.08)	Voltage boost level	0.0%~30.0%【determined by model】	Run&Stop

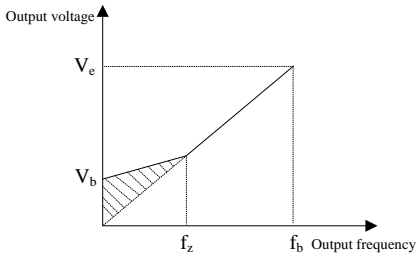

$V_c$ : motor rated voltage

$V_b$ : Boost voltage= $V_c \times P00.22$

$f_z$ : boost close frequency (P06.09)

$f_b$ : rated frequency

Figure 4-1 Voltage boost

Parameter ID	Parameter Name	Range 【Default】	Change Mode
P00.23 (P06.01)	V/F mode setup	0~3 【0】	Stop Only

Different V/F characteristic is defined by P00.23 to meet the demands from different load.

There are three kinds of fixed curve and one user programmed line

When P00.23 (P06.01) is 0, user can define different fold lines by setting P06.02~P06.07, and adding three points, ( $V_1, F_1$ )、 ( $V_2, F_2$ )、 ( $V_3, F_3$ ) to define the V/F lines mode.

- The default V/F is a straight line, as the line 0 in Figure 4-2.
- When P00.23 (P06.01) is set to 1, it is a 2.0 law ramp, as curve 1 in figure 4-2.
- When P00.23 (P06.01) is set to 2, it is a 1.7 law ramp, as curve 2 in figure 4-2.
- When P00.23 (P06.01) is set to 3, it is a 1.2 law ramp, as curve 3 in figure 4-2.



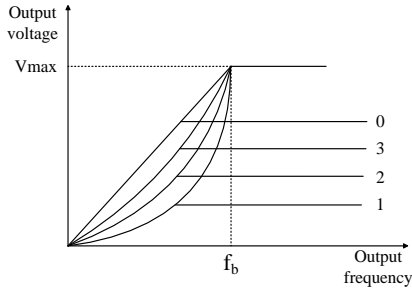

Figure 4-2 Motor V/F curve

Parameter ID	Parameter Name	Range 【Default】	Change Mode
P00.24 (P10.08)	Load default	0~1 【0】	Stop Only

0: No action

1: Load default

When P00.24=1, press PRG key, and default setup will be loaded and saved into the EEPROM, P00.24=0.

NOTE:

- After loading default, except motor parameters, all other parameters are recovered to factory setup;
- After loading default, P00.01 is 0, which means User Code is disable;
- Uploading the parameter setup to the keypad’s EEPROM before loading default is recommended.

## 5 Troubleshooting

### 5.1 Faults and corrective actions

When a drive trip (fault) occurs, the keypad will display the corresponding trip code and drive output will be disabled. HD700 trip is listed in the table 5-1. The range is F001 to F043. If there is a trip, please check the guide in table 5-1 and record the fault carefully. If you need service support, please contact local distributor or supply factory.

Table 5-1 Faults and corrective actions

Trip Code	Trip Description	Possible Reasons	Corrective Actions
F001	Over current Turn off the IGBTs, the drive can be reset 10s after trouble removal	Output short circuit	Check the motor cable and electric connection
		Acceleration or deceleration time is too short	Increase accel or decel time
		The motor is still spinning when the drive is reset after sudden stop	Choose P03.05, and set the start mode to speed tracking and restart
		Internal fault	Contact service center
F002	Over voltage Turn off the IGBTs, the drive can be reset 1s after trouble removal	Supply voltage is too high	Make sure the power supply is within the specification
		Sudden load change	Avoid sudden load changes
		Deceleration time is too short	Increase the deceleration time or add a suitable brake resistor
		Internal fault	Contact service center
F003	Under voltage Turn off the IGBTs, the drive can be reset automatically after trouble removal	Supply voltage is low	Check the power supply
		During drive power off	Normal, and no need to keep in the trip tracking log
		Internal fault	Contact service center

Trip Code	Trip Description	Possible Reasons	Corrective Actions
F004	Input phase loss Stop the drive according to the stop mode, turn off the IGBTs, the drive can be reset 1s after trouble removal	Power supply phase loss	Check the power supply and cabling
F005	Output phase loss Stop the drive according to the stop mode, turn off the IGBTs, the drive can be reset 1s after trouble removal	Output phase loss	Check the output voltage and motor cabling
		Internal fault	Contact service center
F006	Brake unit short circuit Turn off the IGBTs, the drive can be reset 10s after trouble removal	Brake resistor trouble	Check the brake resistance and the cabling
		Internal fault	Contact service center
F007	Heatsink1 over heat, turn off the IGBTs, the drive can be reset 1s after trouble removal	Environmental temperature is high	Reduce the environmental temperature
		Air flow channel blocked	Clean the air flow channel
		Fan failed	Replace the fan
		Internal fault	Contact service center
F008	Heatsink2 over heat(45KW and over), turn off the IGBTs, the drive can be reset 1s after trouble removal	Environment temperature is high	Reduce the environmental temperature
		Air flow channel blocked	Clean the air flow channel
		Fan failed	Replace the fan
		Internal fault	Contact service center

Trip Code	Trip Description	Possible Reasons	Corrective Actions
F009	IGBT junction over heat turn off the IGBTs, the drive can be reset 1s after the trip	Switching frequency is high	Reduce the switching frequency
		Frequently accelerating and decelerating under a heavy load condition	Replace by a larger drive; increase the accel and decel times; enable the auto adjusting function on switching frequency
		Internal fault	Contact service center
F010	Motor overload Stop the drive according to the stop mode, turn off the IGBTs, and the drive can be reset 1s after trouble removal	V/F is not right	Setup V/F and voltage boost correctly
		Supply voltage is low	Check the power supply and cabling
		Motor load is jammed or the load change is excessive	Check the motor load
		The factor for motor overload protecting (P12.12) is set incorrectly	Correct the factor (P12.12)
F011	Motor overheat Stop the drive according to the stop mode, turn off the IGBTs, and the drive can be reset 1s after trouble removal	Load is excessive	Check the load and current
		Motor heat dissipation channel is blocked	Check the motor
		Motor fan is not working	Change the motor fan
		Motor thermistor is faulty	Check the thermistor resistance and replace it
F012	All over current Stop the drive according to the stop mode, turn off the IGBTs, and the drive can reset be 1s after trouble removal	All input current is over 26mA	Check All input

Trip Code	Trip Description	Possible Reasons	Corrective Actions
F013	AII input loosing Stop the drive according to the stop mode, turn off the IGBTs, and the drive can be reset 1s after trouble removal	AII input current is smaller than 3mA	Check AII input
F014	User 24V overload Stop the drive according to the Stop mode, turn off the IGBTs, and the drive can be reset 1s after trouble removal	Output current of 24V and DO1is over 100mA	Check if there is short circuit on the output of DO and 24V
F015	Parameter copying fault the drive can be reset 1s after trouble removal	Parameter copying is abnormal	Power up again
		downloading the parameter setup to the drive when keypad EEPROM is empty	Upload the parameter setup to the keypad, then download
		Inner fault	Contact service center
F016	Auto-tune fault and the drive can be reset 1s after trouble removal	The drive size doesn't match the motor power size	Change the drive
		wrong motor data has been set	Enter correctmotor nameplate data into drive
		Before the auto-tune is finished, user stops the drive	Wait until autotune is finished
F017	Output terminal short circuit at power up	output terminal short circuit	Check wiring and motor insulation
		Current detection fault	Contact service center

Trip Code	Trip Description	Possible Reasons	Corrective Actions
F018	External fault Stop the drive according to the Stop mode, turn off the IGBTs, and the drive can be reset 1s after trouble removal	An external fault input from one of the DI terminals	Check the external equipments
F019	communication fault turn off the IGBTs, and the drive can be reset 1s after trouble removal	linkage fault between the drive and remote keypad or other external options	check the cabling
		communication fault between the drive and remote keypad or other external options	contact service center
F020	EEPROM reading and writing failure	Error occurs when reading & writing the control word	Press STOP key to reset the drive and try again; contact service center
		Internal fault	Contact service center
F021	Assignment fault the drive can be reset 1s after trouble removal	Wrong parameter assignment	<ul style="list-style-type: none"> <li>● Check if parameters are set to the same value, if so, correct it, press STOP key to reset.</li> <li>● Load default, and reset the drive</li> </ul>
F022	Option fault the drive can be reset 1s after trouble removal	wrong option fitting	Fit the correct optional module, try again
		Option failure	Contact service center
F023	Reserved	-	-
F024	internal logic fault turn off the IGBTs, and the drive can reset 1s after trouble removal	internal logic fault	contact service center

Trip Code	Trip Description	Possible Reasons	Corrective Actions
F025~F029	Reserved	–	–
F030	Soft start circuit fault Turn off IGBTs, and the drive can not be reset	Soft start circuit failed	Contact service center
F031	Main fan fault Turn off IGBTs, and the drive cannot be reset	Fan blade not rotating correctly	Check the fan blades
		Wiring is wrong	Check fan wiring
F032	Control fan fault (30kW and above) Turn off IGBTs, and the drive can not be reset	Fan blade not rotating correctly	Check the fan blades
		Wiring is wrong	Check fan wiring; Contact service center
F033	Current sense fault Turn off IGBTs, and the drive can not be reset	Internal fault	Contact service center
F034	Power DSP fault Turn off IGBTs, and the drive can not be reset	Software overflow	Power off and up
		Internal fault	Contact service center
F035	MCU can not receive the data from DSP Turn off IGBTs, and the drive can not be reset	Software error	Contact service center
		MCU or DSP failure	Contact service center
F036	MCU receives wrong data from DSP Turn off IGBTs, and the drive can not be reset	External disturbance	checkcable layout
		Internal fault	Contact service center

Trip Code	Trip Description	Possible Reasons	Corrective Actions
F037	Over current during power up Turn off IGBTs, and the drive can not be reset	Earth fault or current sense circuit failure	Check the output cabling and motor; Contact service center
F038	Wrong drive model Turn off IGBTs, and the drive can not be reset	Internal fault	Contact service center
F039	Internal thermister failed Turn off IGBTs, and the drive can not be reset	IGBT failure	Contact service center
F040	Software exception Turn off IGBTs, and the drive can not be reset	Software error	Contact service center
		MCU or DSP failure	Contact service center
F041	Watchdog failure Turn off IGBTs, and the drive can not be reset	Software error	Contact service center
		MCU or DSP failure	Contact service center
F042	Reserved	–	–
F043	EEPROM internal fault	MCU or DSP failure	Contact service center
	Turn off IGBTs, and the drive can not be reset	EEPROM failure	Contact service center



All above trips can be categorized into 4 types, please see details in table 5-2:

Table 5-2 Fault category

Type	Trips	Description
Fault where the drive can be reset automatically	F003	F003 (under voltage), the drive can be reset automatically according to actual DC bus voltage
Fault where the drive can not be reset	$\geq$ F030	Fault from internal failure (except external disturbance).
EEPROM reading & writing fault	F020	When the trip occurs, user can load default, and then reset the drive.
Ordinary trips	F001, F006	The drive can be reset 10s after trouble removal
	Other trips	The drive can be reset 10s after trouble removal

NOTE:

- F003 can be auto-reset, the under voltage threshold level and hysteresis is different with different rated voltage level.
- When F003 happens, drive starts to save the parameters.
- Only when the drive is active will the trip F003 be recorded in the fault tracking log.
- Menu P11 is for trip tracking.

## 5.2 Alarms

When alarming, the drive will keep running, and the keypad will display relative alarm code (Hxxx), which will keep flashing for 3 seconds then turn over to the normal display (selected by P05.01). The normal display will flash for 3 seconds then return back to flashing alarm code, and this cycle will continue until the alarm is removed. Parameter P12.13 can be set to display the warning information or not.

Table 5-3 Alarm codes and treatments

Codes	Descriptions	Possibilities	Treatments
H001	Current limit is active	Output current is limited at: P7.03×P00.14 (P13.07 Motor1 rated current)	Check the motor cable
			Properly increase the acceleration and deceleration times
			Set P03.05 to the correct start mode (speed tracking and restart)
H002	Motor overload is integrating	Output current is higher than the value of P13.07 (P13.19), until overload trip occurs	Use larger motor and drive
H003	Heatsink is hot	Environment temperature is high	Reduce the environment temperature
		Air flow channel blocked	Unblock the flow channel
		Fan failure	Replace the fan
H004	IGBT junction temperature is high	Frequently accelerating and decelerating	Modify the parameter setup
			Use larger drive
H005	Low DC bus operation (only for 400V models)	Power supply voltage is low	Check the power supply
H006	Reserved	—	—
H007	Sleep mode	The drive is in sleep mode	After the drive is out of sleep mode, the alarm is removed

### 5.3 Other issues

When the drive operates, some other issues which are not caused by drive itself can happen, and the drive will not display trip or alarm code. Customer can check these issues and suggestions in following table 5-4.

Table 5-4 Other issues

Issues	Reasons	Checking And Treatments
Motor does not start	Power issue	Check input voltage, output voltage and unbalance level
		If the motor connection is correct?
		If the busbar link between +DC and +DC1 is fitted correctly?
	Control part	If running order is input?
		If both FWD and REV are input at the same time?
		If the reference is 0?
		If the reference source is analogue, is there correct analogue input signal?
		If P09.21 is set correctly? (correct common point)
	Parameter setup issue	If the control channel is set correctly? (P00.03)
		If the reference source is set correctly? (P00.04)
		If the enable (P03.19) is "1"? And under default setup, check the DI6 is connected to the common?
	Load issue	If overload occurs?
		If the mechanical part is stuck?
Motor torque is not enough	Check if the setup of parameters in menu P06 and P07 is correct?	
Motor makes noise	Drive output voltage unbalance	Check the motor connection
	Mechanical issue	Check the motor and related mechanical parts
	Wrong setup	Check the parameter setup
Motor running direction is abnormal	Motor cabling issue	Check if the output U, V, W matches U, V, W of motor
	Control signal issue	Check if the correct direction order is enabled

Issues	Reasons	Checking And Treatments
Motor accel. or decel. is not stable	Accel. or decel. time is too short	set suitable values for P00.09 and P00.10
	overload	Adjust the load condition
After accel. or decel. operation, speed is not stable	Load issue	Check if the mechanical load keeps changing
	No auto-tune	Do the motor auto-tune
	Motor data setup issue	Check if the motor data are set according to the motor nameplate
parameters can not be written	Change is limited	the parameter can only be changed in stop state
		The parameter property is "actual"
	Keypad is locked	Press and hold ESC key for 5s to disable the keypad lock
	Parameter is not displayed	Set the value of P00.02 to be 1 to display all the parameters
	the user code is enabled	Disable the user code
	Conflicts in parameter setup	Load default and set the parameters correctly
No display on the keypad	Link issue	Check if the link between the keypad and drive, and the keypad are fixed well?
	DC bus busbar link issue	Check if the link between +DC and +DC1 is fitted well

## 6 Maintenance

### 6.1 Routine maintenance

After long time running in different environmental conditions, like high temperature, humidity, dusty, vibration, etc, some internal drive parts could be degrading somehow. This can increase the risk of drive failure or decrease drive life, so it is necessary to do routine and termly maintenance.

Routine maintenance items are as follows:

- If there is noise when motor rotates?
- If there is abnormal vibration during the motor running?
- If the drive installation environment is changed?
- If the drive fan is working well?
- If the drive temperature is higher than normal?

Daily cleaning:

- Try to keep the drive tidy;
- Remove dust from drive surface; avoid dust coming into the drive, especially metal dust;
- Effectively clean the oil stuff from the fan surface.

### 6.2 Periodic check

Base on actual application and environment conditions, customer needs to do termly checking to decrease the risk of drive failure or safety threats. Attention, when the drive is powered off, the powersupply must be disconnected by an approved electrical isolation device before getting access to the electrical connections. Please check details as below,

Table 6-1 Termly checking

Checking Area	Items	Method	Judgment
Environment	temperature, humidity, vibration level	Visual check and using measurement instrument	Must meet the HD700 environment specification
	If there are tools or other stuff around the drive	Visual check	Remove them

Checking Area		Items	Method	Judgment
Voltage		Voltage of power and control parts	Using instruments	Meet the technical specification
Mechanical parts		noise or vibration	Visual check, listening	Normal
		Whether screws or nuts loose	Retighten loosening screws or nuts	Normal
		Whether they are deformed or broken	Visual check, replace	Normal
		Whether colour is changed because of heating	Visual check and replace	Normal
		Whether there is dirt or dust attached?	Visual check and clean	Normal
Power	General	Whether screws or nuts loose	Retighten loosening screws or nuts	Normal
		Whether there is dirt or dust attached to conductors	Clean	Normal
	Power terminal	Whether they are broken?	Visual check and ask for service	Normal
	Brake resistor	Whether there is smell or broken insulator because of heating	Visual check, smell	Normal
		Resistance is normal or not	Multimeter	The resistance should be in $\pm 10\%$ error
	Transformer, reactor	Unusual vibration or smell?	Visual check, listening, smelling	Normal
	Contactor, relay	Cracking noise	listening	Normal
		Contactors are ok?	Visual check	Normal
Cool system	Fan	Whether screws loose	Retighten screws	Normal
		Whether colour is changed because of heating	Visual check	Normal
		noise or vibration	Visual check, listening, making the blades move	Rotating smoothly
	Air flow channel	Whether the heatsink or channel is blocked?	Visual check and clean	Normal

### 6.3 Parts replacement

Inside a drive, different parts have different lifetimes according to normal technique rules, and the actual lifetime is related with operating and environmental conditions, in order to maintain the drive, it is recommended to replace some electrical parts termly, as listed in the following table.

Table 6-2 Parts replacement recommendation

Parts	Recommended replace time
Fan	2 to 3 years
Electrolytic capacitors	4 to 5 years
PCB	5 to 8 years

### 6.4 Drive storage

When user plans to store the drive for a short time or long time, please follow the instructions below:

- It is better to keep the drive in the original factory package.
- After long time storage, the drive's capacitors must be dealt with once again.

NOTE: The starting point of storage time is not purchasing date, but delivery date.

Table 6-3 Actions on drive after storage

Storage Time	Action	Ready Time
half a year	No action	N/A
Half a year to two years	Before running the motor, the drive should be applied to normal voltage for an hour	1 hour
Over two years	Use a variac to apply the voltage on the drive gradually	2 hours

### 6.5 Disposal

Please pay attention when the failed drives are disposal:

- Electrolytic capacitor: when setting fire on the drive electrolytic capacitors, explosion may happen.
- Plastic parts: when firing the plastic parts of the drive, poisonous gas could be released.

Handling method: Please handle the disposal drive as industrial waste.

# Appendix

## 1 Communication

- Communications port and wiring

Hardware interface of HD700 drive communication:

RJ45 port

Two terminals (A/RS485+, B/RS485-)

These two kinds of interface can have the same electric functions.

A serial communications link enables one or more drives to be used in a system controlled by a host controller such as a PLC or computer.

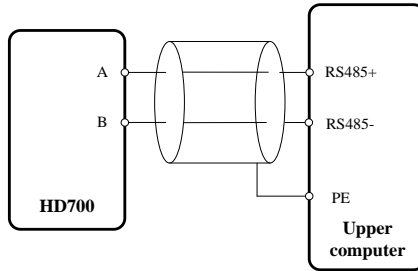

A-figure 1-1 Communications link

NOTE: The RJ45 port pin is as shown in a-figure 1-2, and you can also use parallel line.

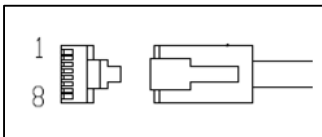

A-figure 1-2 RJ45 port pin configuration diagram

Pin Number	Function
1	NC
2	A (485+)
3	0V
4	24V
5	NC
6	Enable
7	B (485-)
8	B (485-)



- Communication mode

HD700 uses Modbus RTU, which supports to read/write with normal registers. The frame has the following basic format:

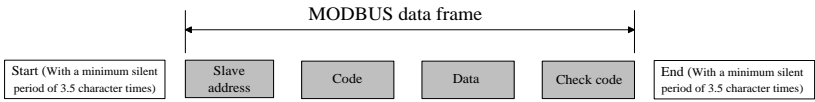

A-figure 1-3 Modbus RTU message format

Modbus RTU uses byte type of "big-endian" to state address and data (except the CRC, which is "little-endian"), and it sends high byte firstly, then low byte.

The frame is terminated with a minimum silent period of 3.5 character times at start and end. Use CRC-16 to check the message information.

- Function codes

The function code determines the different requests.

A-table 1-1 Function code

Code (Hex)	Description
03H	Read multiple registers
06H	Write single register, value changes cannot be saved when drive is powered off
10H	Write multiple registers, value changes cannot be saved when drive is powered off
17H	Read and write multiple registers, value changes cannot be saved when drive is powered off

- Parameter mapping

- The Modbus register address of every parameter is listed in the last column of Parameter list in this manual for user's reference.

The mapping rules between parameter number and register address is as below:

Register address (hexadecimal): MNH

M= decimal convert to hexadecimal from "m"

N= decimal convert to hexadecimal from "n"

"m" and "n" calculation is as below, take parameter Px.y for example,

$$x.y * 100 = m * 256 + n + 1$$

For example:

Modbus register address of parameter P04.01

$$4.01 \times 100 = 401 = 1 \times 256 + 144 + 1$$

Then

$$m=1, n=144$$

by the decimal to hexadecimal converting,

$$M=01, N=90,$$

So, the register address=0190H,

Note: register addresses for all HD700 parameters are in the Appendix3.

- Function code Example 1 (03H)

The example is to read the contents in P04.01~P04.10 of HD700 drive, details are as the table below:

A-table 1-2 Code 03H example

Master Require									
Drive Node	Code	Start Register Address		Number Of Register Read		CRC Checking			
		MSB	LSB	MSB	LSB	LSB	MSB		
01H	03H	01H	90H	00H	0AH	C4H	1CH		
Slave (HD700 drive) Response									
Drive Node	Code	Number Of Register Read	Contents of P04.01~P04.10				Check Sum Of CRC		
			P04.01		.....	P04.10		LSB	MSB
			MSB	LSB		MSB	LSB		
01H	03H	14H	01H	F4H	.....	07H	D0H	B9H	76H

- Function code Example 2 (06H)

The example is to write 8 into P03.27.

A-table 1-3 Function code 06H example

Master Require							
Drive Node	Code	Register Address		Register Data		Check Sum Of CRC	
		MSB	LSB	MSB	LSB	LSB	MSB
01H	06H	01H	46H	00H	08H	68H	25H
Slave (HD700 drive) Response							
Drive Node	Code	Register Address		Register Data		Check Sum Of CRC	
		MSB	LSB	MSB	LSB	LSB	MSB
01H	06H	01H	46H	00H	08H	68H	25H

- Abnormal communication

If the communication is abnormal, HD700 drive will turn back to the response frame, the format is in the below table

A-table 1-4 Abnormal response format

Drive node	Code	Abnormal code	CRC checking sum	
1 bit	1 bit	1 bit	LSB	MSB

A-table 1-5 Abnormal code description

Code	Description
81H	Not supporting the parameter
82H	Register address is beyond limit, the registers being read is too many
83H	The content of register is over limit

- CRC checking

CRC is 16 bit cycle redundance checking, normally the standard CRC-16 is called:  $x^{16}+x^{15}+x^2+1$ . Send the 16 bit CRC message to LSB, do the calculation in a frame of all bits.

const unsigned char auchCRCHi[] = {

```

0x00, 0xC1, 0x81, 0x40, 0x01, 0xC0, 0x80, 0x41, 0x01, 0xC0,
0x80, 0x41, 0x00, 0xC1, 0x81, 0x40, 0x01, 0xC0, 0x80, 0x41,
0x00, 0xC1, 0x81, 0x40, 0x00, 0xC1, 0x81, 0x40, 0x01, 0xC0,
0x80, 0x41, 0x01, 0xC0, 0x80, 0x41, 0x00, 0xC1, 0x81, 0x40,
0x00, 0xC1, 0x81, 0x40, 0x01, 0xC0, 0x80, 0x41, 0x00, 0xC1,
0x81, 0x40, 0x01, 0xC0, 0x80, 0x41, 0x00, 0xC1,
0x81, 0x40, 0x01, 0xC0, 0x80, 0x41, 0x01, 0xC0, 0x80, 0x41,
0x00, 0xC1, 0x81, 0x40, 0x01, 0xC0, 0x80, 0x41, 0x01, 0xC0,
0x80, 0x41, 0x00, 0xC1, 0x81, 0x40, 0x00, 0xC1, 0x81, 0x40,
0x01, 0xC0, 0x80, 0x41, 0x01, 0xC0, 0x80, 0x41, 0x00, 0xC1,
0x81, 0x40, 0x01, 0xC0, 0x80, 0x41, 0x00, 0xC1, 0x81, 0x40,
0x00, 0xC1, 0x81, 0x40, 0x01, 0xC0, 0x80, 0x41, 0x01, 0xC0,
0x80, 0x41, 0x01, 0xC0, 0x80, 0x41, 0x00, 0xC1, 0x81, 0x40,
0x00, 0xC1, 0x81, 0x40, 0x01, 0xC0, 0x80, 0x41, 0x01, 0xC0,
0x80, 0x41, 0x00, 0xC1, 0x81, 0x40, 0x01, 0xC0, 0x80, 0x41,

```

```

0x00, 0xC1, 0x81, 0x40, 0x00, 0xC1, 0x81, 0x40, 0x01, 0xC0,
0x80, 0x41, 0x00, 0xC1, 0x81, 0x40, 0x01, 0xC0, 0x80, 0x41,
0x01, 0xC0, 0x80, 0x41, 0x00, 0xC1, 0x81, 0x40, 0x01, 0xC0,
0x80, 0x41, 0x00, 0xC1, 0x81, 0x40, 0x00, 0xC1, 0x81, 0x40,
0x01, 0xC0, 0x80, 0x41, 0x01, 0xC0, 0x80, 0x41, 0x00, 0xC1,
0x81, 0x40, 0x00, 0xC1, 0x81, 0x40, 0x01, 0xC0, 0x80, 0x41,
0x00, 0xC1, 0x81, 0x40, 0x01, 0xC0, 0x80, 0x41, 0x01, 0xC0,
0x80, 0x41, 0x00, 0xC1, 0x81, 0x40

```

```
};
```

```
//Low-Order Byte Table
```

```
const char auchCRCLo[] = {
```

```

0x00, 0xC0, 0xC1, 0x01, 0xC3, 0x03, 0x02, 0xC2, 0xC6, 0x06,
0x07, 0xC7, 0x05, 0xC5, 0xC4, 0x04, 0xCC, 0x0C, 0x0D, 0xCD,
0x0F, 0xCF, 0xCE, 0x0E, 0x0A, 0xCA, 0xCB, 0x0B, 0xC9, 0x09,
0x08, 0xC8, 0xD8, 0x18, 0x19, 0xD9, 0x1B, 0xDB, 0xDA, 0x1A,
0x1E, 0xDE, 0xDF, 0x1F, 0xDD, 0x1D, 0x1C, 0xDC, 0x14, 0xD4,
0xD5, 0x15, 0xD7, 0x17, 0x16, 0xD6, 0xD2, 0x12, 0x13, 0xD3,
0x11, 0xD1, 0xD0, 0x10, 0xF0, 0x30, 0x31, 0xF1, 0x33, 0xF3,
0xF2, 0x32, 0x36, 0xF6, 0xF7, 0x37, 0xF5, 0x35, 0x34, 0xF4,
0x3C, 0xFC, 0xFD, 0x3D, 0xFF, 0x3F, 0x3E, 0xFE, 0xFA, 0x3A,
0x3B, 0xFB, 0x39, 0xF9, 0xF8, 0x38, 0x28, 0xE8, 0xE9, 0x29,
0xEB, 0x2B, 0x2A, 0xEA, 0xEE, 0x2E, 0x2F, 0xEF, 0x2D, 0xED,
0xEC, 0x2C, 0xE4, 0x24, 0x25, 0xE5, 0x27, 0xE7, 0xE6, 0x26,
0x22, 0xE2, 0xE3, 0x23, 0xE1, 0x21, 0x20, 0xE0, 0xA0, 0x60,
0x61, 0xA1, 0x63, 0xA3, 0xA2, 0x62, 0x66, 0xA6, 0xA7, 0x67,
0xA5, 0x65, 0x64, 0xA4, 0x6C, 0xAC, 0xAD, 0x6D, 0xAF, 0x6F,
0x6E, 0xAE, 0xAA, 0x6A, 0x6B, 0xAB, 0x69, 0xA9, 0xA8, 0x68,
0x78, 0xB8, 0xB9, 0x79, 0xBB, 0x7B, 0x7A, 0xBA, 0xBE, 0x7E,
0x7F, 0xBF, 0x7D, 0xBD, 0xBC, 0x7C, 0xB4, 0x74, 0x75, 0xB5,
0x77, 0xB7, 0xB6, 0x76, 0x72, 0xB2, 0xB3, 0x73, 0xB1, 0x71,
0x70, 0xB0, 0x50, 0x90, 0x91, 0x51, 0x93, 0x53, 0x52, 0x92,
0x96, 0x56, 0x57, 0x97, 0x55, 0x95, 0x94, 0x54, 0x9C, 0x5C,
0x5D, 0x9D, 0x5F, 0x9F, 0x9E, 0x5E, 0x5A, 0x9A, 0x9B, 0x5B,

```

```
    0x99, 0x59, 0x58, 0x98, 0x88, 0x48, 0x49, 0x89, 0x4B, 0x8B,  
    0x8A, 0x4A, 0x4E, 0x8E, 0x8F, 0x4F, 0x8D, 0x4D, 0x4C, 0x8C,  
    0x44, 0x84, 0x85, 0x45, 0x87, 0x47, 0x46, 0x86, 0x82, 0x42,  
    0x43, 0x83, 0x41, 0x81, 0x80, 0x40  
};  
/* CRC Generation for Modbus messages */  
// The function returns the CRC as a unsigned short type  
unsigned short CCRC_ModbusRTUCRC16 (unsigned char *puchMsg, short usDataLen )  
{  
    unsigned short ReturnValue;  
    // high byte of CRC initialized  
    unsigned char uchCRCHi = 0xFF;  
    // low byte of CRC initialized  
    unsigned char uchCRCLo = 0xFF;  
    // will index into CRC lookup table  
    unsigned char uIndex;  
    // pass through message buffer  
    while (usDataLen-->0) {  
        // calculate the CRC  
        uIndex      = uchCRCHi ^ *puchMsg++;  
        uchCRCHi    = uchCRCLo ^ auchCRCHi[ uIndex ];  
        uchCRCLo    = auchCRCLo[ uIndex ];  
    }  
    ReturnValue = uchCRCHi;  
    ReturnValue <<= 8;  
    ReturnValue |= uchCRCLo;  
    return ReturnValue;  
}
```

- HD700 communication parameters

A-table 1-6 HD700 communication parameters

ID	Function	Range	Default	Change Mode	Modbus Address
P00.03 (P10.07)	Control mode	0: Keypad 1: Control terminal 2: Comms.	0	Stop Only	0002H (03EEH)
P00.04 (P01.01)	Reference channel	0: Keypad 1: E-pot 2: Preset 3: AI1 4: AI2 5: Comms. 6: DI7 pulse 7: Fieldbus option 8: User programmed	0	Run&Stop	0003H (0064H)
P03.27	Comms. control word	0~65535	0	Run&Stop	0146H
P03.28	Comms. control word enable	0~1	0	Run&Stop	0147H
P10.02	Address	0~247	1	Run&Stop	03E9H
P10.03	Baud rate	0: 2.4KBPS 1: 4.8KBPS 2: 9.6KBPS 3: 19.2KBPS 4: 38.4KBPS 5: 57.6KBPS	3	Run&Stop	03EAH
P10.04	Communication configuration	0: 8-1-N, RTU, no checking 1: 8-2-N, RTU, no checking 2: 8-1-O, RTU, odd checking 3: 8-1-E, RTU, even checking	1	Run&Stop	03EBH
P10.05	Response delay	0~250ms	2	Run&Stop	03ECH
P10.14	Drive status word	0~65535	Actual	Actual	03F5H

P03.27 and P03.28 provide a method of controlling the sequencer inputs and other functions directly from a single control word. If P03.28 = 0, the control word has no effect, if P03.28 = 1, the control word is enabled. Each bit of the control word corresponds to a sequencing bit or function as shown below,

A-table 1-7 Control word (P03.27) description

Bit	Function
0	Drive enable
1	Run
2	3-wire enable
3	Run forward
4	Run reverse
5	FWD/REV
6	Jog forward
7	Jog reverse
8	Fault reset
9	Saving parameters
10	Clean the trip tracking log
11	Enable comms. to write parameters
12	Reserved
13	Reserved
14	Reserved
15	Reserved

If P10.02 (drive address) = 0, the drive will not response to the master.

A-table 1-8 Drive status (P10.14) description

Bit	Function
0	Drive has no fault
1	Drive is running
2	100% load
3	Frequency is arrived
4	Zero running
5	Running reverse
6	Current limit is working
7	Set time is up
8	Drive control order is changed to control terminal
9	Under voltage

---

Bit	Function
10	Overload is calculating
11	Alarm
12	Length is reached
13	Counting is reached
14	PLC running is over
15	PLC is working

- Scale definition

- Frequency: 1:100

If the drive reference is 50.00Hz, then for hex it is 1388H.

- Time rate: 1:10

If the acceleration rate is 10.0s, then for comms. hex it is 0064H.

- Current rate: 1:10

- Voltage rate: 1:1

If the voltage is 380V, then for comms. hex it is 017CH.



## 2 Parameter list

### Menu P00: Shortcut menu (quick commissioning)

ID	Function	Range	Step	Default	Change Mode	Modbus Register Address
P00.01	Keypad display cycle mode (P05.02)	0: Fixed mode 1: Auto switch mode in running state 2: Reserved	1	0	Run&Stop	0000H
P00.02	Parameter display control (P05.03)	0: Only P00 parameters 1: All menu parameters 2: Only parameters which are different from the default setup	1	1	Run&Stop	0001H
P00.03	Control mode (P10.07)	0: Keypad 1: Control terminal 2: Comms.	1	0	Stop Only	0002H
P00.04	Reference source selector (P01.01)	0: Keypad 1: E-pot 2: Preset 3: AI1 4: AI2 5: Serial comms. 6: DI7 pulse 7: Optional card 8: User programmed	1	0	Run&Stop	0003H

ID	Function	Range	Step	Default	Change Mode	Modbus Register Address
P00.05	AI1 mode selector (P08.02)	0: 0mA~20mA 1: 20 mA~0mA 2: 4mA~20mA (current loosing with trip) 3: 20mA~4mA (current loosing with trip) 4: 4mA~20mA (current loosing without trip) 5: 20mA~4mA (current loosing without trip) 6: 0V~10V	1	6	Stop Only	0004H
P00.06	Preset1 (P04.01)	Min. frequency~300.0Hz	0.01Hz	5.00Hz	Run&Stop	0005H
P00.07	Max. frequency (P01.02)	0.00Hz~300.0Hz	0.01Hz	50.00Hz	Stop Only	0006H
P00.08	Min. frequency (P01.03)	0.00Hz~Max. frequency	0.01Hz	0.00Hz	Stop Only	0007H
P00.09	Accel. time 1 (P02.04)	0.0~3600.0	0.1	10.0	Run&Stop	0008H
P00.10	Decel. time 1 (P02.05)	0.0~3600.0	0.1	20.0	Run&Stop	0009H
P00.11	Stop mode (P03.10)	0: Ramp 1: Coasting 2: Ramp+ DC injection 3: Ramp +coast	1	0	Stop Only	000AH

ID	Function	Range	Step	Default	Change Mode	Modbus Register Address
P00.12	Power up Keypad reference (P01.11)	0: 0.00Hz 1: The running frequency of last power-off 2: Preset 1	1	0	Run&Stop	000BH
P00.13	Motor1 rated voltage (P13.06)	0V~240V 0V~480V 0V~690V	1V	200V: 220V 400V: 380V 690V: 660V	Stop Only	000CH
P00.14	Motor1 rated current (P13.07)	G or P type: 0.1A ~ rated current × 1.2 GP type: 0.1A~P type rated current	0.1A	By model	Stop Only	000DH
P00.15	Motor1 rated frequency (P13.08)	1.00Hz~300.0Hz	0.01Hz	50.00Hz	Stop Only	000EH
P00.16	Motor1 rated speed (P13.10)	1rpm~6000rpm	1rpm	0rpm	Stop Only	000FH
P00.17	Auto-tune (P13.02)	0: No action 1: Static Auto-tune1 2: Static Auto-tune2 3: Reserved	1	0	Stop Only	0010H
P00.18	Motor1 stator resistance (P13.11)	0.000Ω~60.000Ω	0.001Ω	0	Stop Only	0011H
P00.19	Motor1 Power factor (P13.05)	0.00~1.00	0.01	0.85	Stop Only	0012H

ID	Function	Range	Step	Default	Change Mode	Modbus Register Address
P00.20	Motor voltage control mode (P13.01)	0: V/F 1: Open loop vector control 1 2: Open loop vector control 2	1	0	Stop Only	0013H
P00.21	Switch frequency (P10.10)	1kHz~15kHz	1kHz	By model	Run&Stop	0014H
P00.22	Voltage boost (P06.08)	0.0%~30.0%	0.1%	By model	Run&Stop	0015H
P00.23	V/F mode (P06.01)	0: User define V/F 1: 2 law 2: 1.7 law 3: 1.2 law	1	0	Stop Only	0016H
P00.24	Load default (P10.08)	0: No action 1: Load default	1	0	Stop Only	0017H

## Menu P01: Reference

ID	Function	Range	Step	Default	Change Mode	Modbus Register Address
P01.01	Reference source	0: Keypad 1: E-pot 2: Preset 3: AI1 4: AI2 5: Serial comms. 6: DI7 pulse 7: Optional card 8: User programmed	1	0	Run&Stop	0064H
P01.02	Maximum frequency	0.00Hz~300.0Hz	0.01Hz z	50.00 Hz	Stop Only	0065H
P01.03	Minimum frequency	0.00Hz~Max. frequency	0.01Hz z	0.00Hz	Stop Only	0066H
P01.04	Jog frequency	0.00Hz~P01.02	0.01Hz z	5.00Hz	Run&Stop	0067H
P01.05	Skip frequency1	0.00Hz~Max. frequency	0.01Hz z	0.00Hz	Stop Only	0068H
P01.06	Skip frequency2	0.00Hz~Max. frequency	0.01Hz z	0.00Hz	Stop Only	0069H
P01.07	range of skip frequency	0.00Hz~30.00Hz	0.01Hz z	0.00Hz	Stop Only	006AH
P01.08	Reserved	—	—	—	—	—
P01.09	Keypad reference display	-Max. frequency~ + Max. frequency	0.01Hz z	Actual	Actual	006CH
P01.10	E-Pot reference display	-Max. frequency~ + Max. frequency	0.01Hz z	Actual	Actual	006DH

ID	Function	Range	Step	Default	Change Mode	Modbus Register Address
P01.11	Power up keypad reference	0: 0.00Hz 1: Running reference when last power off 2: Preset 1	1	0	Run&Stop	006EH
P01.12	Threshold of zero speed	0.00Hz~Max. frequency	0.01Hz z	0.50Hz	Run&Stop	006FH
P01.13	Band of frequency arrival	0.00Hz~Max. frequency	0.01Hz z	2.50Hz	Run&Stop	0070H
P01.14	Setup reference display	-Max. frequency~ 300.0Hz	0.01Hz z	Actual	Actual	0071H
P01.15	Preset select bit 0 status	0: On 1: Off	1	Actual	Actual	0072H
P01.16	Preset select bit1 status	0: On 1: Off	1	Actual	Actual	0073H
P01.17	Preset select bit2 status	0: On 1: Off	1	Actual	Actual	0074H
P01.18	Preset select bit3 status	0: On 1: Off	1	Actual	Actual	0075H
P01.19	Preset select indicator	Preset1~Preset16	1	Actual	Actual	0076H
P01.20	AI1 reference display	- Max. frequency~ + Max. frequency	0.01Hz z	Actual	Actual	0077H
P01.21	AI2 reference display	- Max. frequency~ + Max. frequency	0.01Hz z	Actual	Actual	0078H
P01.22	RUN/Stop indicator	0: Stop is active 1: Run is active	1	Actual	Actual	0079H
P01.23	Frequency arrival indicator	0: Not arrival 1: Arrival	1	Actual	Actual	007AH

2 Parameter list

ID	Function	Range	Step	Default	Change Mode	Modbus Register Address
P01.24	Zero speed indicator	0: None zero speed 1: At zero speed running	1	Actual	Actual	007BH
P01.25	Reference source is switched to AI1	0: Off 1: On	1	Actual	Actual	007CH
P01.26	Reference source is switched to AI2	0: Off 1: On	1	Actual	Actual	007DH
P01.27	User programmed reference display	- max. frequency~ + max. frequency	0.01Hz	Actual	Actual	007EH
P01.28	Output frequency detection (FDT) threshold	0.00Hz~P01.02	0.01Hz	0.00Hz	Run&Stop	007FH
P01.29	Output frequency detection (FDT) width	0.00Hz~P01.28	0.01Hz	0.00Hz	Run&Stop	0080H
P01.30	Output frequency detection (FDT) indicator	0: Disabled 1: Enabled	1	0	Actual	0080H

## Menu P02: Ramp

ID	Function	Range	Step	Default	Change Mode	Modbus Register Address
P02.01	Acceleration and deceleration mode	0: Line 1: S curve1 2: S curve2 3: special curve	1	0	Stop Only	00C8H
P02.02	Ramp hold	0: Off 1: On	1	0	Actual	00C9H
P02.03	Reserved	—	—	—	—	—
P02.04	Acceleration rate 1	0.0~3600.0	0.1	10.0	Run&Stop	00CBH
P02.05	Deceleration rate 1	0.0~3600.0	0.1	20.0	Run&Stop	00CCH
P02.06	Acceleration rate 2	0.0~3600.0	0.1	30.0	Run&Stop	00CDH
P02.07	Deceleration rate 2	0.0~3600.0	0.1	30.0	Run&Stop	00CEH
P02.08	Acceleration rate 3	0.0~3600.0	0.1	30.0	Run&Stop	00CFH
P02.09	Deceleration rate 3	0.0~3600.0	0.1	30.0	Run&Stop	00D0H
P02.10	Acceleration rate 4	0.0~3600.0	0.1	30.0	Run&Stop	00D1H
P02.11	Deceleration rate 4	0.0~3600.0	0.1	30.0	Run&Stop	00D2H
P02.12	S curve start time	0.0%~40.0%	0.1%	20.0%	Run&Stop	00D3H
P02.13	S curve end time	0.0%~40.0%	0.1%	20.0%	Run&Stop	00D4H
P02.14	Acceleration rate selector bit0 status	0: Off 1: On	1	Actual	Actual	00D5H
P02.15	Acceleration rate selector bit1 status	0: Off 1: On	1	Actual	Actual	00D6H
P02.16	Deceleration rate selector bit0 status	0: Off 1: On	1	Actual	Actual	00D7H
P02.17	Deceleration rate selector bit1 status	0: Off 1: On	1	Actual	Actual	00D8H
P02.18	Jog select indicator	0: Off 1: On	1	Actual	Actual	00D9H
P02.19	Acceleration rate select indicator	Acceleration rate1 to acceleration rate 4	1	Actual	Actual	00DAH



ID	Function	Range	Step	Default	Change Mode	Modbus Register Address
P02.20	Deceleration rate select indicator	Deceleration rate 1 to deceleration rate 4	1	Actual	Actual	00DBH
P02.21	Acceleration rate & deceleration rate unit selector	0: Second 1: Minute	1	0	Stop Only	00DCH
P02.22	Jog acceleration rate	0.1s~600.0s	0.1s	10.0s	Run&Stop	00DDH
P02.23	Jog deceleration rate	0.1s~600.0s	0.1s	10.0s	Run&Stop	00DEH
P02.24	Jog interval time	0.1s~600.0s	0.1s	0.1s	Run&Stop	00DFH
P02.25	UP/DN output negative permit	0: Only positive 1: Negative permit	1	0	Run&Stop	00E0H
P02.26	UP/DN Acceleration rate	0.0s~250.0s	1.0s	10.0s	Run&Stop	00E1H
P02.27	UP/DN output scaling	0.000~4.000	0.001	1.000	Run&Stop	00E2H
P02.28	Function selector of UP/DN output	P00.00~P18.08	0.01	P01.10	Stop Only	00E3H
P02.29	Reset of UP/DN output	0: Off 1: On	1	0	Actual	00E4H
P02.30	UP	0: Off 1: On	1	0	Actual	00E5H
P02.31	DN	0: Off 1: On	1	0	Actual	00E6H
P02.32	UP/DN output display	-100.0% ~ +100.0%	0.1%	Actual	Stop Only	00E7H

ID	Function	Range	Step	Default	Change Mode	Modbus Register Address
P02.33	UP/DNreference	0: 0 1: Running reference of last power-off 2: 0, only can be changed when drive is active 3: Running reference of last power-off, only can be changed when drive is active 4: Preset 1, UP, DOWN and reset are active at all times 5: Preset 1, UP, DOWN are only active when the drive is running. Reset is active at all times.	1	0	Run&Stop	00E8H
P02.34	Power off UP/DN output selector	0: Keep 1: Reset	1	0	Run&Stop	00E9H

## Menu P03: Start and stop

ID	Function	Range	Step	Default	Change Mode	Modbus Register Address
P03.01	Reverse limit control	0: Reverse is permitted 1: Reverse is disabled	1	0	Stop Only	012CH
P03.02	Dead time for running direction change	0.0s~3000.0s	0.1s	0.0s	Run&Stop	012DH
P03.03	Auto-start after power off	0: Off 1: enable function 1 2: enable function2	1	0	Stop Only	012EH
P03.04	Waiting time for auto-start	0.0s~60.0s	0.1s	0.0s	Run&Stop	012FH
P03.05	Start mode	0: Start directly 1: First DC injection, then start 2: speed tracking and restart 3: Reserved 4: Reserved	1	0	Stop Only	0130H
P03.06	Start frequency	0.00Hz~P01.02	0.01Hz	0.00Hz	Run&Stop	0131H
P03.07	Hold time for start frequency	0.0s~60.0s	0.1s	0.0s	Run&Stop	0132H
P03.08	Start DC injection current	0.0%~300.0% (refer to the motor rated current)	0.1%	0.0%	Run&Stop	0133H
P03.09	Start DC injection time	0.0s~60.0s	0.1s	0.0s	Run&Stop	0134H

ID	Function	Range	Step	Default	Change Mode	Modbus Register Address
P03.10	Stop mode	0: Ramp 1: Coast 2: Ramp+DC injection 3: Ramp+coast	1	0	Stop Only	0135H
P03.11	Stop frequency	0.00Hz~Max. frequency	0.01Hz	0.10Hz	Run&Stop	0136H
P03.12	Stop DC injecting frequency	0.0%~100.0% (refer to the max. frequency)	0.1%	0.0%	Run&Stop	0137H
P03.13	Stop DC injecting current	0.0%~300.0% (refer to the motor rated current)	0.1%	0.0%	Run&Stop	0138H
P03.14	Stop DC injecting time	0.0s~60.0s	0.1s	0.0s	Run&Stop	0139H
P03.15	Dynamic brake control	0: Disabled 1: Enabled	1	1	Stop Only	013AH
P03.16	Dynamic brake rate	0.0%~100.0%	0.1%	50.0%	Run&Stop	013BH
P03.17	Dynamic brake DC voltage points	200V: 350V~390V 400V: 650V~780V 690V: 1000V~1125V	1V	200V: 390V 400V: 780V 690V: 1125V	Stop Only	013CH
P03.18	Reserved	—	—	—	—	—
P03.19	Enable	0: On 1: Off (disabled)	1	0	Actual	013EH
P03.20	Run bit	0: Off 1: On	1	0	Actual	013FH
P03.21	3-wire enable	0: Stop 1: Run	1	0	Actual	0140H

2 Parameter list

ID	Function	Range	Step	Default	Change Mode	Modbus Register Address
P03.22	FWD	0: Off 1: On	1	0	Actual	0141H
P03.23	REV	0: Off 1: On	1	0	Actual	0142H
P03.24	FWD/REV	0: Forward 1: Reverse	1	0	Actual	0143H
P03.25	Jog forward	0: Off 1: On	1	0	Actual	0144H
P03.26	Jog reverse	0: Off 1: On	1	0	Actual	0145H
P03.27	Comms control word	0~65535	1	0	Actual	0146H
P03.28	Control word enable	0: Disabled 1: Enabled	1	0	Run&Stop	0147H
P03.29	Reserved	–	–	–	–	–
P03.30	Reverse running indicator	0: Forward 1: Reverse	1	Actual	Actual	0149H

## Menu P04: Preset and PLC

ID	Function	Range	Step	Default	Change Mode	Modbus Register Address
P04.01	Preset1	Min. frequency to Max. frequency	0.01Hz	5.00Hz	Run&Stop	0190H
P04.02	Preset 2		0.01Hz	10.00Hz	Run&Stop	0191H
P04.03	Preset 3		0.01Hz	20.00Hz	Run&Stop	0192H
P04.04	Preset 4		0.01Hz	30.00Hz	Run&Stop	0193H
P04.05	Preset 5		0.01Hz	40.00Hz	Run&Stop	0194H
P04.06	Preset 6		0.01Hz	45.00Hz	Run&Stop	0195H
P04.07	Preset 7		0.01Hz	50.00Hz	Run&Stop	0196H
P04.08	Preset 8		0.01Hz	5.00Hz	Run&Stop	0197H
P04.09	Preset 9		0.01Hz	10.00Hz	Run&Stop	0198H
P04.10	Preset 10		0.01Hz	20.00Hz	Run&Stop	0199H
P04.11	Preset 11		0.01Hz	30.00Hz	Run&Stop	019AH
P04.12	Preset 12		0.01Hz	40.00Hz	Run&Stop	019BH
P04.13	Preset 13		0.01Hz	45.00Hz	Run&Stop	019CH
P04.14	Preset 14		0.01Hz	50.00Hz	Run&Stop	019DH
P04.15	Preset 15		0.01Hz	50.00Hz	Run&Stop	019EH
P04.16	Preset 16		0.01Hz	50.00Hz	Run&Stop	019FH
P04.17	PLC mode	0: Disabled 1: Single cycle then stop 2: Single cycle and keep the last speed 3: Recycle	1	0	Stop Only	01A0H
P04.18	PLC power off saving mode	0: Power off without saving 1: Power off with saving	1	1	Stop Only	01A1H
P04.19	PLC restart mode	0: From first step speed 1: From the step speed which is the one at last stop (trip) 2: From the speed which is the one at last stop (trip)	1	0	Stop Only	01A2H

ID	Function	Range	Step	Default	Change Mode	Modbus Register Address
P04.20	PLC step1 running time	0.0~6553.5	0.1	0.0	Run&Stop	01A3H
P04.21	PLC step1 Accel./Decel. rate selector	0: Accel./Decel. rate 1 1: Accel./Decel. rate 2 2: Accel./Decel. rate 3 3: Accel./Decel. rate 4	1	0	Run&Stop	01A4H
P04.22	PLC step2 running time	0.0~6553.5	0.1	0.0	Run&Stop	01A5H
P04.23	PLC step2 Accel./Decel. rate selector	0: Accel./Decel. rate 1 1: Accel./Decel. rate 2 2: Accel./Decel. rate 3 3: Accel./Decel. rate 4	1	0	Run&Stop	01A6H
P04.24	PLC step3 running time	0.0~6553.5	0.1	0.0	Run&Stop	01A7H
P04.25	PLC step3 Accel./Decel. rate selector	0: Accel./Decel. rate 1 1: Accel./Decel. rate 2 2: Accel./Decel. rate 3 3: Accel./Decel. rate 4	1	0	Run&Stop	01A8H
P04.26	PLC step4 running time	0.0~6553.5	0.1	0.0	Run&Stop	01A9H
P04.27	PLC step4 Accel./Decel. rate selector	0: Accel./Decel. rate 1 1: Accel./Decel. rate 2 2: Accel./Decel. rate 3 3: Accel./Decel. rate 4	1	0	Run&Stop	01AAH
P04.28	PLC step5 running time	0.0~6553.5	0.1	0.0	Run&Stop	01ABH
P04.29	PLC step5 Accel./Decel. rate selector	0: Accel./Decel. rate 1 1: Accel./Decel. rate 2 2: Accel./Decel. rate 3 3: Accel./Decel. rate 4	1	0	Run&Stop	01ACH

ID	Function	Range	Step	Default	Change Mode	Modbus Register Address
P04.30	PLC step6 running time	0.0~6553.5	0.1	0.0	Run&Stop	01ADH
P04.31	PLC step6 Accel./ Decel. Rate selector	0: Accel./Decel. rate 1 1: Accel./Decel. rate 2 2: Accel./Decel. rate 3 3: Accel./Decel. rate 4	1	0	Run&Stop	01AEH
P04.32	PLC step7 running time	0.0~6553.5	0.1	0.0	Run&Stop	01AFH
P04.33	PLC step7 Accel./ Decel. rate selector	0: Accel./Decel. rate 1 1: Accel./Decel. rate 2 2: Accel./Decel. rate 3 3: Accel./Decel. rate 4	1	0	Run&Stop	01B0H
P04.34	PLC step8 running time	0.0~6553.5	0.1	0.0	Run&Stop	01B1H
P04.35	PLC step8 Accel./ Decel. Rate selector	0: Accel./Decel. rate 1 1: Accel./Decel. rate 2 2: Accel./Decel. rate 3 3: Accel./Decel. rate 4	1	0	Run&Stop	01B2H
P04.36	PLC step9 running time	0.0~6553.5	0.1	0.0	Run&Stop	01B3H
P04.37	PLC Step9 Accel./ Decel. Rate selector	0: Accel./Decel. rate 1 1: Accel./Decel. rate 2 2: Accel./Decel. rate 3 3: Accel./Decel. rate 4	1	0	Run&Stop	01B4H
P04.38	PLC step10 running time	0.0~6553.5	0.1	0.0	Run&Stop	01B5H
P04.39	PLC step10 Accel./ Decel. Rate selector	0: Accel./Decel. rate 1 1: Accel./Decel. rate 2 2: Accel./Decel. rate 3 3: Accel./Decel. rate 4	1	0	Run&Stop	01B6H



2 Parameter list

ID	Function	Range	Step	Default	Change Mode	Modbus Register Address
P04.40	PLC step11 running time	0.0~6553.5	0.1	0.0	Run&Stop	01B7H
P04.41	PLC step11 Accel./Decel. Rate selector	0: Accel./Decel. rate 1 1: Accel./Decel. rate 2 2: Accel./Decel. rate 3 3: Accel./Decel. rate 4	1	0	Run&Stop	01B8H
P04.42	PLC step12 running time	0.0~6553.5	0.1	0.0	Run&Stop	01B9H
P04.43	PLC step12 Accel./Decel. rate selector	0: Accel./Decel. rate 1 1: Accel./Decel. rate 2 2: Accel./Decel. rate 3 3: Accel./Decel. rate 4	1	0	Run&Stop	01BAH
P04.44	PLC step13 running time	0.0~6553.5	0.1	0.0	Run&Stop	01BBH
P04.45	PLC step13 Accel./Decel. rate selector	0: Accel./Decel. rate 1 1: Accel./Decel. rate 2 2: Accel./Decel. rate 3 3: Accel./Decel. rate 4	1	0	Run&Stop	01BCH
P04.46	PLC step14 running time	0.0~6553.5	0.1	0.0	Run&Stop	01BDH
P04.47	PLC step14 Accel./Decel. rate selector	0: Accel./Decel. rate 1 1: Accel./Decel. rate 2 2: Accel./Decel. rate 3 3: Accel./Decel. rate 4	1	0	Run&Stop	01BEH
P04.48	PLC step15 running time	0.0~6553.5	0.1	0.0	Run&Stop	01BFH
P04.49	PLC step15 Accel./Decel. rate selector	0: Accel./Decel. rate 1 1: Accel./Decel. rate 2 2: Accel./Decel. rate 3 3: Accel./Decel. rate 4	1	0	Run&Stop	01C0H

ID	Function	Range	Step	Default	Change Mode	Modbus Register Address
P04.50	PLC step16 running time	0.0~6553.5	0.1	0.0	Run&Stop	01C1H
P04.51	PLC step16 Accel./Decel. Rate selector	0: Accel./Decel. rate 1 1: Accel./Decel. rate 2 2: Accel./Decel. rate 3 3: Accel./Decel. rate 4	1	0	Run&Stop	01C2H
P04.52	PLC operating time unit	0: Second 1: Hour	1	0	Run&Stop	01C3H
P04.53	PLC finished indicator	0: Not finished 1: Finished	1	Actual	Actual	01C4H
P04.54	PLC recycle mode indicator	0: No-recycle 1: Recycle	1	Actual	Actual	01C5H
P04.55	PLC reset indicator	0: off 1: on	1	Actual	Actual	01C6H

## Menu P05: Keypad and display

ID	Function	Range	Step	Default	Change Mode	Modbus Register Address
P05.01	Normal keypad display selector	P01.01~P18.08	0.01	P05.11	Run&Stop	01F4H
P05.02	Keypad cycle display mode	0~2	1	0	Run&Stop	01F5H
P05.03	Parameter display range control	0: Only menu P00 1: All menus parameters 2: Only parameters which is different with default	1	1	Run&Stop	01F6H
P05.04	Parameter copying	0: No action 1: uploading parameters to keypad 2: downloading parameters to the drive	1	0	Stop Only	01F7H
P05.05	LCD language	0: Chinese 1: English 2: Reserved	1	0	Run&Stop	01F8H
P05.06	Keypad lock control	0: Unlock 1: All keys are locked 2: Except RUN&STOP, all other keys are locked	1	0	Run&Stop	01F9H
P05.07	MF switch function select	0: Jog 1: FWD/REV 2: Coasting Stop 3: Reserved	1	0	Run&Stop	01FAH
P05.08	Motor speed	-18000rpm~+18000rpm	1rpm	Actual	Actual	01FBH
P05.09	Factor for load speed	0.1%~1000%	0.1%	100.0%	Run&Stop	01FCH

ID	Function	Range	Step	Default	Change Mode	Modbus Register Address
P05.10	Mechanical load speed	-180000rpm~ +180000rpm	1rpm	Actual	Actual	01FDH
P05.11	Running frequency	-max. frequency~ +max. frequency	0.01Hz	Actual	Actual	01FEH
P05.12	Output voltage	0V~Drive rated voltage	1V	Actual	Actual	01FFH
P05.13	DC voltage	200V: 230V~415V 400V: 250V~830V 690V: 400V~1190V	1V	Actual	Actual	0200H
P05.14	Output current	0.0A~3×motor rated current	0.1A	Actual	Actual	0201H
P05.15	Torque current	0.0A~3×motor rated current	0.1A	Actual	Actual	0202H
P05.16	Magnetizing current	-3×motor rated current~+3×motor rated current	0.1A	Actual	Actual	0203H
P05.17	Output power	0.0%~300.0% (refer to motor rated power)	0.1%	Actual	Actual	0204H
P05.18	Operation time log: year. day	0.000~9.364 year.day	0.001 y.d	Actual	Actual	0205H
P05.19	Operation time log: hour. minute	0.00~23.59hour.minute	0.01 h.m	Actual	Actual	0206H
P05.20	Energy meter: MWh	0.0MWh~999.9MWh	0.1 MWh	Actual	Actual	0207H
P05.21	Energy meter: kWh	0.00kWh~99.99kWh	0.01 kWh	Actual	Actual	0208H
P05.22	Electric price/kWh	0.0~0.99(currency/kWh)	0.01	0.00	Run&Stop	0209H

## 2 Parameter list

ID	Function	Range	Step	Default	Change Mode	Modbus Register Address
P05.23	Energy meter reset	0: No action 1: Reset	1	0	Run&Stop	020AH
P05.24	Average running cost	0~100 (currency)	1	Actual	Actual	020BH
P05.25	Heatsink temperature	-25°C ~127°C	1°C	Actual	Actual	020CH
P05.26	IGBT junction temperature	-25°C ~200°C	1°C	Actual	Actual	020DH
P05.27	Drive is running	0: Drive is at ready or trip stage 1: Drive is running	1	Actual	Actual	020EH
P05.28	Rated load is reached	0: Output current is less than motor rated current 1: Output current equals motor rated current	1	Actual	Actual	020FH
P05.29	Control MCU software version	0.00~99.99	0.01	Actual	Actual	0210H
P05.30	Power MCU software version	0.00~99.99	0.01	Actual	Actual	0211H
P05.31	LCD software version	0.00~99.99	0.01	Actual	Actual	0212H
P05.32	Brigde rectifier software version	0.00~99.99	0.01	Actual	Actual	0213H

## Menu P06: V/F controls parameters

ID	Function	Range	Step	Default	Change Mode	Modbus Register Address
P06.01	V/F control mode	0: User programmed V/F ramp 1: 2 law ramp 2: 1.7 law ramp 3: 1.2 law ramp	1	0	Stop Only	0258H
P06.02	V/F frequency 3	(P06.04)~(P13.08)	0.01Hz	0.00Hz	Stop Only	0259H
P06.03	V/F voltage3	(P06.05)~100.0% (refer to motor rated voltage)	0.1%	0.0%	Stop Only	025AH
P06.04	V/F frequency 2	(P06.06)~(P06.02)	0.01Hz	0.00Hz	Stop Only	025BH
P06.05	V/F voltage 2	(P06.07)~(P06.03)	0.1%	0.0%	Stop Only	025CH
P06.06	V/F frequency 1	0.00~(P06.04)	0.01Hz	0.00Hz	Stop Only	025DH
P06.07	V/F voltage 1	0~(P06.05)	0.1%	0.0%	Stop Only	025EH
P06.08	Voltage boost	0.0%~30.0% (refer to motor rated voltage)	0.1%	By model	Run&Stop	025FH
P06.09	Boost finish frequency	0.0%~50.0% (refer to motor rated voltage)	0.1%	50.0%	Run&Stop	0260H
P06.10	Stable factor control	0: Off 1: On	1	0	Run&Stop	0261H
P06.11	Auto energy saving control	0: Off 1: On	1	0	Stop Only	0262H
P06.12	AVR control	0: Off 1: On for all condition 2: On except ramp	1	1	Stop Only	0263H

NOTE: (Pxx.xx) means the value of Pxx.xx.

## Menu P07: Vector

ID	Function	Range	Step	Default	Change Mode	Modbus Register Address
P07.01	Speed/Torque mode change condition	0: Only stop 1: Run&stop	1	0	Run&Stop	02BCH
P07.02	Speed/Torque control	0: Speed 1: Torque	1	0	Run&Stop	02BDH
P07.03	Current limit	0.0% ~300.0% (refer to motor rated current)	0.1%	By model	Run&Stop	02BEH
P07.04 ~ P07.11	Reserved	—	—	—	—	—
P07.12	Current controller Kp gain	0.001 ~10.000	0.001	0.020	Run&Stop	02C7H
P07.13	Current controller Ki gain	0.00s ~100.00s	0.01s	0.20s	Run&Stop	02C8H
P07.14	Current limit protection	0: Enable current limit protection 1: Disable current limit protection above fundamental frequency 2: Fast increase or decrease current limit protection disabled 3: Both disabled	1	0	Stop Only	02C9H
P07.15	Slip compensation error	0rpm ~1500rpm	1rpm	0rpm	Run&Stop	02CAH
P07.16	Active current limit	0.0% ~300.0%	0.1%	200.0%	Run&Stop	02CBH

ID	Function	Range	Step	Default	Change Mode	Modbus Register Address
P07.17	Regen. Current limit	0.0% ~300.0%	0.1%	150.0%	Run&Stop	02CCH
P07.18	Maximum speed under torque mode	0.00Hz~1.2×P01.02	0.01Hz	50.00 Hz	Run&Stop	02CDH
P07.19	Torque mode reference source	0: Keypad 1: AI1 2: AI2 3: Pulse (DI7) 4: Serial comms. 5: User programmed 6: Optional module	1	1	Stop Only	02CEH
P07.20	Torque gain	0.0% ~300.0%	0.1%	100.0%	Run&Stop	02CFH
P07.21	Torque offset	0.0% ~100.0%	0.1%	0.0%	Run&Stop	02D0H
P07.22	Torque reference display	-300.0% ~+300.0%	0.1%	Actual	Actual	02D1H
P07.23	Reserved	-	-	-	-	-
P07.24	Torque is being limited	0: Not limited 1: Being limited	1	Actual	Actual	02D3H



## Menu P08: Analogue input and output

ID	Function	Range	Step	Default	Change Mode	Modbus Register Address
P08.01	Analogue input function level control	0: P08.03 and P08.08 are only basic function (0~3) 1: P08.03 and P08.08 are advanced application (P00.00~P18.08)	1	0	Run&Stop	0320H
P08.02	AI1 mode	0: 0mA~20mA 1: 20mA~0mA 2: 4mA~20mA (current loosing with trip) 3: 20mA~4mA (current loosing with trip) 4: 4mA~20mA (current loosing without trip) 5: 20mA~4mA (current loosing without trip) 6: 0V~10V	1	6	Stop Only	0321H
P08.03	AI1 function select	0: Analogue input1 1: Speed limit (Torque control) 2: Torque offset 3: No function 99*: Advanced function	1	0	Stop Only	0322H
P08.04	AI11 offset	-200.0%~+200.0%	0.1%	0.0%	Run&Stop	0323H
P08.05	AI1 scaling	0.000~20.000	0.001	1.000	Run&Stop	0324H
P08.06	AI1 inverter	0: Off 1: On	1	0	Run&Stop	0325H
P08.07	AI1 filtering time	0.00s~10.00s	0.01s	0.1s	Run&Stop	0326H

ID	Function	Range	Step	Default	Change Mode	Modbus Register Address
P08.08	AI2 function select	0: Analogue input2 1: Speed limit (Torque control) 2: Torque offset 3: No function 99*: Advanced function	1	0	Stop Only	0327H
P08.09	AI2 offset	-200.0%~+200.0%	0.1%	0.0%	Run&Stop	0328H
P08.10	AI2 scaling	0.000~20.000	0.001	1.000	Run&Stop	0329H
P08.11	AI2 inverter	0: Off 1: On	1	0	Run&Stop	032AH
P08.12	AI2 filtering time	0.00s~10.00s	0.01s	0.1s	Run&Stop	032BH
P08.13	Analogue output function level control	0: P08.14 is only basic application (0~11) 1: P08.14 is advanced application (P00.00~P18.08)	1	0	Run&Stop	032CH

2 Parameter list

ID	Function	Range	Step	Default	Change Mode	Modbus Register Address
P08.14	Analogue output function select	0: Output frequency 1: Reference frequency 2: Active current 3: Output current 4: Motor speed 5: DC voltage 6: Output voltage 7: AI1 level 8: AI2 level 9: Length 10: Counting 11: No function 99*: Advanced function	1	0	Run&Stop	032DH
When AO1 select the following function and 100% output						
		0: Output frequency	Maximum running frequency			
		1: Reference frequency	Maximum running frequency			
		2: Active current	3 times motor rated current			
		3: Output current	3 times motor rated current			
		4: Motor speed	The motor speed (rpm) is calculated according to the maximum frequency			
		5: DC voltage	220: 415V			
			400: 830V			
			690: 1125V			
		6: Output voltage	Motor rated voltage			
		7: AI1 level	10V			
		8: AI2 level	10V			
		9: Length	60000			
		10: Counting	60000			
P08.15	Analogue output scaling	0.000~20.000	0.001	1.000	Run&Stop	032EH

ID	Function	Range	Step	Default	Change Mode	Modbus Register Address
P08.16	Current loosing indicator	0: No loosing 1: Loosing	1	Actual	Actual	032FH
P08.17	AI1 level	0.0% ~ 100.0%	0.1%	Actual	Actual	0330H
P08.18	AI2 level	0.0% ~ 100.0%	0.1%	Actual	Actual	0331H
P08.19	Analogue output level	0.0% ~ 100.0%	0.1%	Actual	Actual	0332H
P08.20	AI1 upper limit	0.0% ~ 100.0%	0.1%	100.0%	Run&Stop	0333H
P08.21	AI1 lower limit	0.0% ~ P08.20	0.1%	0.0%	Run&Stop	0334H
P08.22	AI2 upper limit	0.0% ~ 100.0%	0.1%	100.0%	Run&Stop	0335H
P08.23	AI2 lower limit	0.0% ~ P08.22	0.1%	0.0%	Run&Stop	0336H

\*NOTE: For parameters P08.03, P08.08, P08.14, when the advanced function returns to basic function, if there is no corresponding options, will display “99”, and the advanced function will continue to take effect.

Menu P09: Digital input and output

ID	Function	Range	Step	Default	Change Mode	Modbus Register Address
P09.01	Digit input function level control	0: P09.02 to P09.08 are base application (0~19) 1: P09.02~P09.08 are advanced application (P00.00~P18.08)	1	0	Run&Stop	0384H
P09.02	DI1 function	0: Preset select bit 0 1: Preset select bit 1 2: Run	1	DI1: 3	Stop Only	0385H
P09.03	DI2 function	3: Run forward (FWD) 4: Run reverse (REV) 5: 3-wire enable		DI2: 4		0386H
P09.04	DI3 function	6: FWD/REV 7: Jog forward 8: UP		DI3: 7		0387H
P09.05	DI4 function	9: DOWN 10: Enable 11: Reset		DI4: 0		0388H
P09.06	DI5 function	12: Control channel is switched to terminal 13: Reset length counting		DI5: 1		0389H
P09.07	DI6 function	14: Reset number counting		DI6: 10		038AH
P09.08	DI7 function	15: External trip 16: Preset select bit2 17: Preset select bit3 18: PLC reset indicator 19: No function 99*: Advanced function		DI7: 11		038BH

ID	Function	Range	Step	Default	Change Mode	Modbus Register Address
P09.09	Status relays function level control	0: P09.10~P09.11 are basic application (0~12) 1: P09.10~P09.11 advanced application (P00.00~P18.08)	1	0	Run&Stop	038CH
P09.10	Relay1 function	0: Drive healthy 1: Drive is active 2: Length arrival 3: External trip 4: Under voltage trip 5: PLC finished 6: Frequency is arrival	1	Relay1: 0	Run&Stop	038DH
P09.11	Relay2 function	7: Torque limit is working 8: Time arrival 9: Overload is calculating 10: At zero speed 11: Brake logic is on 12: No function 99*: Advanced function		Relay2: 1		038EH
P09.12	DI1 inverter	0: Off 1: On	1	0	Run&Stop	038FH
P09.13	DI2 inverter	0: Off 1: On	1	0	Run&Stop	0390H
P09.14	DI3 inverter	0: Off 1: On	1	0	Run&Stop	0391H
P09.15	DI4 inverter	0: Off 1: On	1	0	Run&Stop	0392H
P09.16	DI5 inverter	0: Off 1: On	1	0	Run&Stop	0393H
P09.17	DI6 inverter	0: Off 1: On	1	0	Run&Stop	0394H

2 Parameter list

ID	Function	Range	Step	Default	Change Mode	Modbus Register Address
P09.18	DI7 inverter	0: Off 1: On	1	0	Run&Stop	0395H
P09.19	Relay1 inverter	0: Off 1: On	1	0	Run&Stop	0396H
P09.20	Relay2 inverter	0: Off 1: On	1	0	Run&Stop	0397H
P09.21	DI common select	0: 0V 1: 24V	1	0	Stop Only	0398H
P09.22	3-wire mode	0: Disabled 1: 3-wire 1 2: 3-wire 2	1	0	Stop Only	0399H
P09.23	DI6 mode	0: Normal digit 1: Length counting pulse 2: Number counting pulse	1	0	Run&Stop	039AH
P09.24	DI7 mode	0: Normal digit 1: Motor thermister 2: High frequency pulse	1	0	Run&Stop	039BH
P09.25	Reserved	—	—	—	—	—
P09.26	Reserved	—	—	—	—	—
P09.27	DI7 maximum frequency of input pulse	0.1kHz~50.0kHz	0.1 kHz	10.0kHz	Run&Stop	039EH
P09.28	DI7 center of frequency of input pulse	0: No center 1: Center = P09.27/2, frequency less than center is negative 2: Center = P09.27/2, frequency less than center is positive	1	0	Run&Stop	039FH

ID	Function	Range	Step	Default	Change Mode	Modbus Register Address
P09.29	Digital output function level control	0: P09.30~P09.31 is base application (0~8) 1: P09.30~P09.31 is advanced application (P00.00~P18.08)	1	0	Run&Stop	03A0H
P09.30	DO1 function	0: PLC is running recycle 1: Drive is active 2: Drive is alarming 3: 100% current 4: Drive healthy	1	DO1: 6	Run&Stop	03A1H
P09.31	DO2 function	5: Length counting arrival 6: Running at zero speed 7: Brake logic is on 8: No function 99*: Advanced function				DO2: 2
P09.32	DO1 inverter	0: Off 1: On	1	0	Run&Stop	03A3H
P09.33	DO2 inverter	0: Off 1: On	1	0	Run&Stop	03A4H
P09.34	DO2 maximum frequency of output pulse	0.1kHz~50.0kHz	0.1 kHz	10.0kHz	Run&Stop	03A5H
P09.35	DO2 output mode selection	0: Digital signal output 1: Pulse output 2: PWM output	1	0	Run&Stop	03A6H
P09.36	Reserved	—	—	—	—	—
P09.37	Reserved	—	—	—	—	—



## 2 Parameter list

ID	Function	Range	Step	Default	Change Mode	Modbus Register Address
P09.38	DI7 level of input frequency	-100.0% ~ +100.0%	0.1%	Actual	Actual	03A9H
P09.39	Reserved	-	-	-	-	-
P09.40	DI1 status	0: Off 1: On	1	Actual	Actual	03ABH
P09.41	DI2 status	0: Off 1: On	1	Actual	Actual	03ACH
P09.42	DI3 status	0: Off 1: On	1	Actual	Actual	03ADH
P09.43	DI4 status	0: Off 1: On	1	Actual	Actual	03AEH
P09.44	DI5 status	0: Off 1: On	1	Actual	Actual	03AFH
P09.45	DI6 status	0: Off (P09.23≠0) 1: On	1	Actual	Actual	03B0H
P09.46	DI7 status	0: Off (P09.24≠0) 1: On	1	Actual	Actual	03B1H
P09.47	Relay1 status	0: Off 1: On	1	Actual	Actual	03B2H
P09.48	Relay2 status	0: Off 1: On	1	Actual	Actual	03B3H
P09.49	DO1 status	0: Output 0V 1: Output 24V	1	Actual	Actual	03B4H
P09.50	DO2 status	0: Output 0V(P09.35≠0) 1: Output 24V	1	Actual	Actual	03B5H

\*NOTE: For parameters P08.03, P08.08, P08.14, when the advanced function returns to basic function, if there is no corresponding options, will display “99”, and the advanced function will continue to take effect.

## Menu P10: Comms. and general function

ID	Function	Range	Step	Default	Change Mode	Modbus Register Address
P10.01	Protocol	0: Modbus RTU 1: Reserved	1	0	Run&Stop	03E8H
P10.02	Address	0~247	1	1	Run&Stop	03E9H
P10.03	Baud rate	0: 2.4KBPS 1: 4.8KBPS 2: 9.6KBPS 3: 19.2KBPS 4: 38.4KBPS 5: 57.6KBPS	1	3	Run&Stop	03EAH
P10.04	Comms. configuration	0: 8-1-N, RTU, without checking 1: 8-2-N, RTU, without checking 2: 8-1-0, RTU, with odd bit checking 3: 8-1-E, RTU, with even bit checking	1	1	Run&Stop	03EBH
P10.05	Response delay time	0ms~250ms	1ms	2ms	Run&Stop	03ECH
P10.06	User Code	0~9999	1	0	Run&Stop	03EDH
P10.07	Control mode	0: Keypad 1: Control terminal 2: Serial communication	1	0	Stop Only	03EEH
P10.08	Load default	0: Off 1: Load default	1	0	Stop Only	03EFH
P10.09	Fan control	0: Under control 1: Forced running	1	0	Run&Stop	03F0H
P10.10	Switch frequency	1kHz~15kHz	1kHz	By model	Run&Stop	03F1H

ID	Function	Range	Step	Default	Change Mode	Modbus Register Address
P10.11	Switch frequency auto adjust	0: Off 1: On	1	1	Run&Stop	03F2H
P10.12	Low DC bus operation (only for 400V models)	0: Off 1: On	1	0	Stop Only	03F3H
P10.13	Model code	0~255	1	By model	Actual	03F4H
P10.14	Drive status	0~65535	1	Actual	Actual	03F5H
P10.15	Set operation time	0~P10.25	1	0	Run&Stop	03F6H
P10.16	Set time is meet	0: No 1: Meet	1	Actual	Actual	03F7H
P10.17	Control channel is switched to terminal	0: No action 1: Control channel is terminal	1	Actual	Actual	03F8H
P10.18	Keypad disconnected with drive	0: Carry on running 1: Stop Note: Keypad control mode.	1	1	Stop Only	03F9H
P10.19	Load default after remove User Code by hardware	0: No 1: Load default	1	0	Run&Stop	03FAH
P10.20	Forced DC brake	0: Off 1: On	1	Actual	Actual	03FBH
P10.21	PID output keep	0: Off 1: On	1	Actual	Actual	03FCH

ID	Function	Range	Step	Default	Change Mode	Modbus Register Address
P10.22	Power off stop mode	0: Coasting stop 1: Ramp stop	1	0	Stop Only	03FDH
P10.23	Cumulative running time reset	0: Off 1: On	1	0	Run&Stop	03FEH
P10.24	Set the unit of running time	0: Hour 1: Second	1	0	Stop Only	03FFH
P10.25	Set running time upper limit	0~60000	1	1000	Stop Only	0400H
P10.26	Motor Director setup	0: FWD 1: REV	1	0	Stop Only	0401H

## Menu P11: Fault Tracking

ID	Function	Range	Step	Default	Change Mode	Modbus Register Address
P11.01	Trip 1	0~99	1	0	Actual	044CH
P11.02	Trip 2					044DH
P11.03	Trip 3					044EH
P11.04	Trip 4					044FH
P11.05	Trip 5					0450H
P11.06	Trip 6					0451H
P11.07	Trip 7					0452H
P11.08	Trip 8					0453H
P11.09	Trip 9					0454H
P11.10	Last trip					0455H
P11.11	Last trip frequency	-P01.02~+P01.02	0.01Hz	Actual	Actual	0456H
P11.12	Last trip current	0.0A~3×motor rated current	0.1A	Actual	Actual	0457H
P11.13	Last trip DC bus voltage	200V: 0~415V 400V: 0~830V 690V: 0~1150V	1V	Actual	Actual	0458H
P11.14	Last trip digital input terminals status	0~255	1	Actual	Actual	0459H
P11.15	Last trip digital output terminals status	0~255	1	Actual	Actual	045AH
P11.16	Present failure logging	0~99	1	0	Actual	045BH

## Menu P12: Protection

ID	Function	Range	Step	Default	Change Mode	Modbus Register Address
P12.01	Drive healthy	0: Off 1: On	1	Actual	Actual	04B0H
P12.02	Ramp hold by high voltage threshold	0: Off 1: On	1	1	Stop Only	04B1H
P12.03	high voltage threshold	220V: 350V~370V 400V: 750V~780V 690V: 1000V~1125V	1	220V: 370V 400V: 780V 690V: 1125V	Stop Only	04B2H
P12.04	Pre-overload alarm	0: Off 1: On	1	1	Stop Only	04B3H
P12.05	Pre-overload threshold	80.0%~150.0%	0.1%	130.0%	Run&Stop	04B4H
P12.06	Pre-overload delay time	0.0s~60.0s	0.1s	5.0s	Run&Stop	04B5H
P12.07	Auto reset	1~100	1	0	Stop Only	04B6H
P12.08	Auto reset delay	2.0s~20.0s	0.1s	5.0	Stop Only	04B7H
P12.09	Input phase loss delay	0.0s~3000.0s	0.1s	0.1s	Stop Only	04B8H
P12.10	Output phase loss	0: Off 1: On	1	0	Stop Only	04B9H
P12.11	Motor overload protection mode	0: Normal motor 1: Variable frequency motor	1	1	Stop Only	04BAH
P12.12	Overload factor	0~(drive rated current/motor rated current)×100%	1	100%	Run&Stop	04BBH

2 Parameter list

ID	Function	Range	Step	Default	Change Mode	Modbus Register Address
P12.13	Alarm display control	0: Not display 1: Display	1	1	Run&Stop	04BCH
P12.14	External fault	0: Off 1: On	1	0	Run&Stop	04BDH
P12.15	Reset trip	0: Off 1: On	1	0	Stop Only	04BEH
P12.16	Under voltage indicator	0: Off 1: On	1	Actual	Actual	04BFH
P12.17	Overload accumulator indicator	0: Off 1: On	1	Actual	Actual	04C0H
P12.18	Alarm indicator	0: Off 1: On	1	Actual	Actual	04C1H
P12.19	Power off undervoltage fault disable	0: Enabled 1: Disabled	1	0	Run&Stop	04C2H

## Menu P13: Motor

ID	Function	Range	Step	Default	Change Mode	Modbus Register Address
P13.01	Motor voltage control mode	0: V/F 1: Open loop vector control 1 2: Open loop vector control 2	1	0	Stop Only	0514H
P13.02	Auto-tune	0: Disabled 1: Auto-tune 1 (run a time) 2: Auto-tune 2 (run once a time) 3: Reserved	1	0	Stop Only	0515H
P13.03	Motor 1/ motor 2 select	0: Motor 1 1: Motor 2	1	0	Stop Only	0516H
P13.04	Reserved	—	—	—	—	—
P13.05	Motor 1 power factor	0.00~1.00	0.01	0.85	Stop Only	0518H
P13.06	Motor 1 rated voltage	200V: 0V~240V 400V: 0V~480V 690V: 0V~690V	1V	200V: 220V 400V: 380V 690V: 660V	Stop Only	0519H
P13.07	Motor 1 rated current	G or P type: 0.1A~rated current ×1.2 GP type: 0.1A~P type rated current	0.1A	By model	Stop Only	051AH
P13.08	Motor 1 rated frequency	1.00Hz~300.0Hz	0.01Hz	50.00Hz	Stop Only	051BH



2 Parameter list

ID	Function	Range	Step	Default	Change Mode	Modbus Register Address
P13.09	Number of motor 1 pairs of pole	0: Auto 1: 2 pole 2: 4 pole 3: 6 pole 4: 8 pole	1	2	Stop Only	051CH
P13.10	Motor 1 rated speed	1rpm~60000rpm	1rpm	0rpm	Stop Only	051DH
P13.11	Motor 1 stator resistance	0.000Ω~60.000Ω	0.001Ω	0	Stop Only	051EH
P13.12	Reserved	—	—	—	—	—
P13.13	Motor 1 transient inductance	0.00%~50.00%	0.01%	by model	Stop Only	0520H
P13.14 ~ P13.16	Reserved	—	—	—	—	—
P13.17	Motor 2 power factor	0.00~1.00	0.01	0.85	Stop Only	0524H
P13.18	Motor 2 rated voltage	200V: 0V~240V 400V: 0V~480V 690V: 0V~690V	1V	200V: 220V 400V: 380V 690V: 660V	Stop Only	0525H
P13.19	Motor 2 rated current	G or P type: 0.1A~rated current×1.2 GP type: 0.1A~P type rated current	0.1A	by model	Stop Only	0526H
P13.20	Motor 2 rated frequency	1.00Hz~300.0Hz	0.01Hz	50.00Hz	Stop Only	0527H

ID	Function	Range	Step	Default	Change Mode	Modbus Register Address
P13.21	Number of motor 2 pairs of pole	0: Auto 1: 2 pole 2: 4 pole 3: 6 pole 4: 8 pole	1	2	Stop Only	0528H
P13.22	Motor 2 rated speed	1rpm~60000rpm	1rpm	0rpm	Stop Only	0529H
P13.23	Motor 2 stator resistance	0.000Ω~60.000Ω	0.001Ω	0	Stop Only	052AH
P13.24	Reserved	—	—	—	—	—
P13.25	Reserved	—	—	—	—	—
P13.26	Motor2 transient inductance	0.00%~50.00%	0.01%	by model	Stop Only	052DH

## Menu P14: Textile function

ID	Function	Range	Step	Default	Change Mode	Modbus Register Address
P14.01	Textile function enable	0: Off 1: On	1	0	Stop Only	0578H
P14.02	Centre of textile frequency	0.00Hz~Max. frequency	0.01Hz	0.00Hz	Run&Stop	0579H
P14.03	Preset textile frequency	0.00Hz~Max. frequency	0.01Hz	0.00Hz	Run&Stop	057AH
P14.04	Run time of Preset textile frequency	0.0s~3600.0s	0.1s	0.0s	Run&Stop	057BH
P14.05	Textile frequency	0.0%~50.0% (map to P14.02)	0.1%	0.0%	Run&Stop	057CH
P14.06	Jump frequency	0.0%~50.0% (map to P14.05)	0.1%	0.0%	Run&Stop	057DH
P14.07	Textile period	0.1 s~1000.0s	0.1s	10.0s	Run&Stop	057EH
P14.08	Triangle rise time	0.0%~100.0% (map to P14.07)	0.1%	50.0%	Run&Stop	057FH
P14.09	Pause textile	0: Off 1: On	1	0	Run&Stop	0580H
P14.10	Reference of length	0~P14.20	1	1000	Run&Stop	0581H
P14.11	Actual length	0~30000	1	Actual	Actual	0582H
P14.12	Pulse number per unit length	0.1~P14.21	0.1	100.0	Run&Stop	0583H
P14.13	Actual length meets the reference	0: P14.11 < P14.10 1: P14.11 ≥ P14.10	1	Actual	Actual	0584H
P14.14	Reference of number counting	1~P14.22	1	1000	Run&Stop	0585H
P14.15	Set number	1~P14.14	1	1000	Run&Stop	0586H

ID	Function	Range	Step	Default	Change Mode	Modbus Register Address
P14.16	Actual number meets reference number	0: Less than P14.14 1: Equals P14.14	1	Actual	Actual	0587H
P14.17	Actual number meets set number	0: Less than P14.15 1: Equals P14.15	1	Actual	Actual	0588H
P14.18	Reset length counting	0: Off 1: On	1	0	Run&Stop	0589H
P14.19	Reset number counting	0: Off 1: On	1	0	Run&Stop	058AH
P14.20	Reference length upper limit	0~30000	1	1000	Stop Only	058BH
P14.21	Pulse number per unit length upper limit	0.1~3000.0	0.1	100.0	Stop Only	058CH
P14.22	Reference number counting upper limit	1~30000	1	1000	Stop Only	058DH

## Menu P15: PID Controller

ID	Function	Range	Step	Default	Change Mode	Modbus Register Address
P15.01	PID reference source	P00.00~P18.08	0.01	P00.00*	Run&Stop	05DCH
P15.02	PID feedback source	P00.00~P18.08	0.01	P00.00*	Run&Stop	05DDH
P15.03	Main Reference to be modified	P00.00~P18.08	0.01	P00.00*	Run&Stop	05DEH
P15.04	PID reference inverter	0: Off 1: On	1	0	Run&Stop	05DFH
P15.05	PID feedback inverter	0: Off 1: On	1	0	Run&Stop	05E0H
P15.06	PID reference slew rate	0.0s~3200.0s	0.1s	0.0	Run&Stop	05E1H
P15.07	PID enable	0: Off 1: On	1	0	Run&Stop	05E2H
P15.08	Reserved	—	—	—	—	—
P15.09	PID proportional gain	0.000~4.000	0.001	1.000	Run&Stop	05E4H
P15.10	PID integral gain	0.000~4.000	0.001	0.500	Run&Stop	05E5H
P15.11	PID derivative gain	0.000~4.000	0.001	0.000	Run&Stop	05E6H
P15.12	PID upper limit	0.0 % ~ 100.0%	0.1	100.0%	Run&Stop	05E7H
P15.13	PID lower limit	-100.0% ~ +100.0%	0.1	0%	Run&Stop	05E8H
P15.14	PID output scaling	0.000~4.000	0.001	1.000	Run&Stop	05E9H
P15.15	PID output function	P00.00~P18.08	0.01	P00.00*	Run&Stop	05EAH

ID	Function	Range	Step	Default	Change Mode	Modbus Register Address
P15.16	PID hold	0: Off 1: On	1	0	Run&Stop	05EBH
P15.17	P15.12, P15.13 range	0: $(P15.13) \leq (P15.22)$ $\leq (P15.12)$ 1: $-(P15.12) \leq (P15.22) \leq (P15.12)$	1	0	Run&Stop	05ECH
P15.18	Main reference level	-100.0% ~ +100.0%	0.1%	Actual	Actual	05EDH
P15.19	PID reference level	-100.0% ~ +100.0%	0.1%	Actual	Actual	05EEH
P15.20	PID feedback level	-100.0% ~ +100.0%	0.1%	Actual	Actual	05EFH
P15.21	PID error level	-100.0% ~ +100.0%	0.1%	Actual	Actual	05F0H
P15.22	PID output level	-100.0% ~ +100.0%	0.1%	Actual	Actual	05F1H
P15.23	Sleep mode enable	0: Off 1: On	1	0	Stop Only	05F2H
P15.24	Sleep channel selector	P00.00 ~ P18.08	0.01	P05.11	Stop Only	05F3H
P15.25	Sleep threshold	0.00Hz ~ P01.02 (P15.24 = P05.11) 0.0% ~ 100.0% (P15.24 = other)	0.01Hz 0.1%	0.00Hz 0.0%	Stop Only	05F4H
P15.26	Sleep delay time	0.0s ~ 3000.0s	0.1s	30.0s	Stop Only	05F5H
P15.27	Wakeup mode	0: Off 1: On	1	1	Stop Only	05F6H
P15.28	Weakeup channel selector	P00.00 ~ P18.08	0.01	P15.20	Stop Only	05F7H
P15.29	Wakeup threshold	0.0% ~ 100.0%	0.1%	0.0%	Stop Only	05F8H
P15.30	Wakeup delay time	0.0s ~ 3000.0s	0.1s	0.0s	Stop Only	05F9H

## 2 Parameter list

---

<b>ID</b>	<b>Function</b>	<b>Range</b>	<b>Step</b>	<b>Default</b>	<b>Change Mode</b>	<b>Modbus Register Address</b>
P15.31	Reserved	–	–	–	–	–
P15.32	Reserved	–	–	–	–	–
P15.33	Reserved	–	–	–	–	–
P15.34	Sleep status indicator	0: Not sleep mode 1: Sleep mode	1	Actual	Actual	05FDH

NOTE: (Pxx.xx) means the value of Pxx.xx.

\*NOTE: There is no actual parameter P00.00. The source default P00.00 means to disable the PID.

## Menu P16: Programmable logic and binary sum

ID	Function	Range	Step	Default	Change Mode	Modbus Register Address
P16.01	block1 source1	P00.00~P18.08	0.01	P00.00*	Stop Only	0640H
P16.02	block1 source1 inverter	0: Off 1: On	1	0	Run&Stop	0641H
P16.03	block1 source2	P00.00~P18.08	0.01	P00.00*	Stop Only	0642H
P16.04	block1 source2 inverter	0: Off 1: On	1	0	Run&Stop	0643H
P16.05	block1 output inverter	0: Off 1: On	1	0	Run&Stop	0644H
P16.06	block1 output delay	±3000.0s	0.1s	0.0s	Run&Stop	0645H
P16.07	block1 output function	P00.00~P18.08	0.01	P00.00*	Stop Only	0646H
P16.08	Block2 source1	P00.00~P18.08	0.01	P00.00*	Stop Only	0647H
P16.09	Block2 source1 inverter	0: Off 1: On	1	0	Run&Stop	0648H
P16.10	Block2 source2	P00.00~P18.08	0.01	P00.00*	Stop Only	0649H
P16.11	Block2 source2 inverter	0: Off 1: On	1	0	Run&Stop	064AH
P16.12	Block2 output inverter	0: Off 1: On	1	0	Run&Stop	064BH
P16.13	Block2 output delay	±3000.0s	0.1s	0.0	Run&Stop	064CH
P16.14	Block2 output function	P00.00~P18.08	0.01	P00.00*	Stop Only	064DH
P16.15	Sum one's input	0: Off 1: On	1	0	Run&Stop	064EH
P16.16	Sum two's input	0: Off 1: On	1	0	Run&Stop	064FH
P16.17	Sum four's input	0: Off 1: On	1	0	Run&Stop	0650H
P16.18	Binary sum offset	0~248	1	0	Run&Stop	0651H



## 2 Parameter list

---

<b>ID</b>	<b>Function</b>	<b>Range</b>	<b>Step</b>	<b>Default</b>	<b>Change Mode</b>	<b>Modbus Register Address</b>
P16.19	Sum output function	P00.00~P18.08	0.01	P00.00*	Stop Only	0652H
P16.20	Block1 output indicator	0: Off 1: On	1	Actual	Actual	0653H
P16.21	Block2 output indicator	0: Off 1: On	1	Actual	Actual	0654H
P16.22	Sum output level	0~255	1	Actual	Actual	0655H

\*NOTE: There is no actual parameter P00.00. The source default P00.00 means to disable the PID.

## Menu P17: Threshold and variable selector

ID	Function	Range	Step	Default	Change Mode	Modbus Register Address
P17.01	Threshold block1 source	P00.00~P18.08	0.01	P00.00*	Stop Only	06A4H
P17.02	Threshold block1 threshold	0.0%~100.0%	0.1%	0.0	Run&Stop	06A5H
P17.03	Threshold block1 hysteresis	0.0%~25.0%	0.1%	0.0	Run&Stop	06A6H
P17.04	Threshold block1 output inverter	0: Off 1: On	1	0	Run&Stop	06A7H
P17.05	Threshold block1 output function	P00.00~P18.08	0.01	P00.00*	Stop Only	06A8H
P17.06	Threshold block2 source	P00.00~P18.08	0.01	P00.00*	Stop Only	06A9H
P17.07	Threshold block2 threshold	0.0%~100.0%	0.1%	0.0	Run&Stop	06AAH
P17.08	Threshold block2 hysteresis	0.0%~25.0%	0.1%	0.0	Run&Stop	06ABH
P17.09	Threshold block2 output inverter	0: Off 1: On	1	0	Run&Stop	06ACH
P17.10	Threshold block2 output function	P00.00~P18.08	0.01	P00.00*	Stop Only	06ADH
P17.11	Variable selector1 source1	P00.00~P18.08	0.01	P00.00*	Stop Only	06AEH
P17.12	Variable selector1 source2	P00.00~P18.08	0.01	P00.00*	Stop Only	06AFH
P17.13	Variable selector1 source1 scaling	-5.000~+5.000	0.001	1.000	Run&Stop	06B0H
P17.14	Variable selector1 source2 scaling	-5.000~+5.000	0.001	1.000	Run&Stop	06B1H

2 Parameter list

ID	Function	Range	Step	Default	Change Mode	Modbus Register Address																																																
P17.15	Variable selector1 mode	0~9	1	0	Run&Stop	06B2H																																																
<table border="1"> <thead> <tr> <th>P17.15</th> <th>Action</th> <th colspan="2">Result</th> </tr> </thead> <tbody> <tr> <td>0</td> <td>Select input1</td> <td colspan="2">output=input1</td> </tr> <tr> <td>1</td> <td>Select input 2</td> <td colspan="2">output=input2</td> </tr> <tr> <td>2</td> <td>Add</td> <td colspan="2">output=input1+ input2</td> </tr> <tr> <td>3</td> <td>Subtract</td> <td colspan="2">output=input1-input2</td> </tr> <tr> <td>4</td> <td>Multiply</td> <td colspan="2">output=(input1 ×input2)/100</td> </tr> <tr> <td>5</td> <td>Divide</td> <td colspan="2">output=(input1 ×100)/ input2</td> </tr> <tr> <td>6</td> <td>Time constant</td> <td colspan="2">output=input1/[(P17.16) ×s+1]</td> </tr> <tr> <td>7</td> <td>Linear ramp</td> <td colspan="2">output=Input1 ramp up from 0% ~100% in time of (P17.16)</td> </tr> <tr> <td>8</td> <td>Modulus</td> <td colspan="2">output= input1 </td> </tr> <tr> <td rowspan="3">9</td> <td rowspan="3">Raise to power</td> <td>P17.16=0.02</td> <td>output=(input1)<sup>2</sup>/100</td> </tr> <tr> <td>P17.16=0.03</td> <td>output=(input1)<sup>3</sup>/100<sup>2</sup></td> </tr> <tr> <td>P17.16 has any other value</td> <td>output=input1</td> </tr> </tbody> </table>							P17.15	Action	Result		0	Select input1	output=input1		1	Select input 2	output=input2		2	Add	output=input1+ input2		3	Subtract	output=input1-input2		4	Multiply	output=(input1 ×input2)/100		5	Divide	output=(input1 ×100)/ input2		6	Time constant	output=input1/[(P17.16) ×s+1]		7	Linear ramp	output=Input1 ramp up from 0% ~100% in time of (P17.16)		8	Modulus	output= input1		9	Raise to power	P17.16=0.02	output=(input1) <sup>2</sup> /100	P17.16=0.03	output=(input1) <sup>3</sup> /100 <sup>2</sup>	P17.16 has any other value	output=input1
P17.15	Action	Result																																																				
0	Select input1	output=input1																																																				
1	Select input 2	output=input2																																																				
2	Add	output=input1+ input2																																																				
3	Subtract	output=input1-input2																																																				
4	Multiply	output=(input1 ×input2)/100																																																				
5	Divide	output=(input1 ×100)/ input2																																																				
6	Time constant	output=input1/[(P17.16) ×s+1]																																																				
7	Linear ramp	output=Input1 ramp up from 0% ~100% in time of (P17.16)																																																				
8	Modulus	output= input1																																																				
9	Raise to power	P17.16=0.02	output=(input1) <sup>2</sup> /100																																																			
		P17.16=0.03	output=(input1) <sup>3</sup> /100 <sup>2</sup>																																																			
		P17.16 has any other value	output=input1																																																			
Note: (P17.16) means the value of P17.16.																																																						
P17.16	Variable selector1 control factor	0.00~99.99	0.01	0.00	Run&Stop	06B3H																																																
P17.17	Variable Selector1 output function	P00.00~P18.08	0.01	P00.00*	Stop Only	06B4H																																																
P17.18	Variable selector2 source1	P00.00~P18.08	0.01	P00.00*	Stop Only	06B5H																																																
P17.19	Variable selector2 source2	P00.00~P18.08	0.01	P00.00*	Stop Only	06B6H																																																
P17.20	Variable selector2 source1 scaling	-5.000~+5.000	0.001	1.000	Run&Stop	06B7H																																																
P17.21	Variable selector2 source2 scaling	-5.000~+5.000	0.001	1.000	Run&Stop	06B8H																																																
P17.22	Variable selector2 mode	0~9	1	0	Run&Stop	06B9H																																																

ID	Function	Range	Step	Default	Change Mode	Modbus Register Address
P17.22	Action	Result				
0	Select input1	output=input1				
1	Select input 2	output=input2				
2	Add	output=input1+ input2				
3	Subtract	output=input1-input2				
4	Multiply	output=(input1×input2)/100				
5	Divide	output=(input1×100)/input2				
6	Time constant	output=input1/[(P17.23)×s+1]				
7	Linear ramp	output=Input1 ramp up from 0%~100% in time of (P17.23)				
8	Modulus	output= input1				
9	Raise to power	P17.23=0.02		output=(input1) <sup>2</sup> /100		
		P17.23=0.03		output=(input1) <sup>3</sup> /100 <sup>2</sup>		
		P17.23 has any other value		output=input1		
P17.23	Variable selector2 control factor	0.00~99.99	0.01	0.00	Run&Stop	06BAH
P17.24	Variable Selector2 output function	P00.00~P18.08	0.01	P00.00*	Stop Only	06BBH
P17.25	Variable selector3 source1	P00.00~P18.08	0.01	P00.00*	Stop Only	06BCH
P17.26	Variable selector3 source2	P00.00~P18.08	0.01	P00.00*	Stop Only	06BDH
P17.27	Variable selector3 source1 scaling	-5.000~+5.000	0.001	1.000	Run&Stop	06BEH
P17.28	Variable selector3 source2 scaling	-5.000~+5.000	0.001	1.000	Run&Stop	06BFH
P17.29	Variable selector3 mode	0~9	1	0	Run&Stop	06C0H

Note: (P17.23) means the value of P17.23.

ID	Function	Range	Step	Default	Change Mode	Modbus Register Address
P17.29	Action	Result				
0	Select input1	output=input1				
1	Select input 2	output=input2				
2	Add	output=input1+ input2				
3	Subtract	output=input1-input2				
4	Multiply	output=(input1×input2)/100				
5	Divide	output=(input1×100)/input2				
6	Time constant	output=input1/[(P17.30)×s+1]				
7	Linear ramp	output=Input1 ramp up from 0%~100% in time of (P17.30)				
8	Modulus	output= input1				
9	Raise to power	P17.30=0.02		output=(input1) <sup>2</sup> /100		
		P17.30=0.03		output=(input1) <sup>3</sup> /100 <sup>2</sup>		
		P17.30 has any other value		output=input1		
Note: (P17.30) means the value of P17.30.						
P17.30	Variable selector3 control factor	0.00~99.99	0.01	0.00	Run&Stop	06C1H
P17.31	Variable selector3 output function	P00.00~P18.08	0.01	P00.00*	Stop Only	06C2H
P17.32	Threshold block1 output indicator	0, 1	1	Actual	Actual	06C3H
P17.33	Threshold block2 output indicator	0, 1	1	Actual	Actual	06C4H
P17.34	Variable selector1 output level	-100.0%~+100.0%	0.1%	Actual	Actual	06C5H
P17.35	Variable selector2 output level	-100.0%~+100.0%	0.1%	Actual	Actual	06C6H
P17.36	Variable selector3 output level	-100.0%~+100.0%	0.1%	Actual	Actual	06C7H
P17.37	User-defined bit variable 1	0~1	1	0	Run&Stop	06C8H

ID	Function	Range	Step	Default	Change Mode	Modbus Register Address
P17.38	User-defined bit variable 2	0~1	1	0	Run&Stop	06C9H
P17.39	User-defined bit variable 3	0~1	1	0	Run&Stop	06CAH
P17.40	User-defined bit variable 4	0~1	1	0	Run&Stop	06CBH
P17.41	User-defined bit variable 5	0~1	1	0	Run&Stop	06CCH
P17.42	User-defined word variable 1	-300.0%~300.0%	0.1%	0.0%	Run&Stop	06CDH
P17.43	User-defined word variable 2	-300.0%~300.0%	0.1%	0.0%	Run&Stop	06CEH
P17.44	User-defined word variable 3	-300.0%~300.0%	0.1%	0.0%	Run&Stop	06CFH
P17.45	User-defined word variable 4	-300.0%~300.0%	0.1%	0.0%	Run&Stop	06D0H
P17.46	User-defined word variable 5	-300.0%~300.0%	0.1%	0.0%	Run&Stop	06D1H

\*NOTE: There is no actual parameter P00.00. The source default P00.00 means to disable the PID.

## Menu P18: Brake logic control

ID	Function	Range	Step	Default	Change Mode	Modbus Register Address
P18.01	Brake controller enable	0: Off 1: On	1	0	Stop Only	0708H
P18.02	Brake release current threshold	0% ~200%	1%	50%	Run&Stop	0709H
P18.03	Brake apply current threshold	0% ~200%	1%	10%	Run&Stop	070AH
P18.04	Brake release frequency threshold	0.00Hz~20.00Hz	0.01Hz	1.00Hz	Run&Stop	070BH
P18.05	Brake apply frequency threshold	0.00Hz~20.00Hz	0.01Hz	2.00Hz	Run&Stop	070CH
P18.06	Pre-brake release delay	0.0s~25.0s	0.1s	1.0s	Run&Stop	070DH
P18.07	Post-brake release delay	0.0s~25.0s	0.1s	1.0s	Run&Stop	070EH
P18.08	Brake logic indicator	0: Apply 1: Release	1	Actual	Actual	070FH

### 3 Multistage velocity setup guide

Controlled by terminals, the reference is the value of P04.01 (preset 1) ~P04.16 (preset 16).

Use the default setup as an example:

P09.05=0      DI4 is preset select bit 0

P09.06=1      DI5 is preset select bit 1

There are two operation modes:

- When the reference source is preset, terminal status is as shown below:

Table 4-1    Preset and preset terminal status corresponding table 1

DI5 Status (bit 1)	DI4 Status (bit 0)	Speed
OFF	OFF	Preset 1 (P04.01)
OFF	ON	Preset 2 (P04.02)
ON	OFF	Preset 3 (P04.03)
ON	ON	Preset 4 (P04.04)

- When the reference source is not preset, terminal status is as shown below:

Table 4-2    Preset and preset terminal status corresponding table 2

DI5 Status (bit 1)	DI4 Status (bit 0)	Speed
OFF	OFF	Keep the frequency setting
OFF	ON	Preset 2 (P04.02)
ON	OFF	Preset 3 (P04.03)
ON	ON	Preset 4 (P04.04)

For 16 presets (P04.01~P04.16) control, please refer to Menu P04.

#### 16 multistage velocity setup guide:

When setting up P01.01 = 2 (reference source is multistage velocity), set up

DI4 controls multistage velocity 0

DI5 controls multistage velocity 1

DI6 controls multistage velocity 2

DI7 controls multistage velocity 3

Or set up advanced application function of digital input terminal, set up

Advanced application of digital input terminal

DI4 controls multistage velocity 0

DI5 controls multistage velocity 1

DI6 controls multistage velocity 2

DI7 controls multistage velocity 3



Digital input terminal DI4~DI7 control values of P01.15~P01.18, thus controlling the value of P01.19, achieving **16** multistage velocity running.

With either setup above, the corresponding relationship between DI4~DI7 status (P01.15~P01.18) and multistage velocity is shown in following table.

Preset and the preset terminal mapping table

<b>P01.18</b>	<b>P01.17</b>	<b>P01.16</b>	<b>P01.15</b>	<b>Reference selector</b>	<b>P01.19</b>
OFF	OFF	OFF	OFF	Preset1	1
OFF	OFF	OFF	ON	Preset2	2
OFF	OFF	ON	OFF	Preset3	3
OFF	OFF	ON	ON	Preset4	4
OFF	ON	OFF	OFF	Preset5	5
OFF	ON	OFF	ON	Preset6	6
OFF	ON	ON	OFF	Preset7	7
OFF	ON	ON	ON	Preset8	8
ON	OFF	OFF	OFF	Preset9	9
ON	OFF	OFF	ON	Preset10	10
ON	OFF	ON	OFF	Preset11	11
ON	OFF	ON	ON	Preset12	12
ON	ON	OFF	OFF	Preset13	13
ON	ON	OFF	ON	Preset14	14
ON	ON	ON	OFF	Preset15	15
ON	ON	ON	ON	Preset16	16

# User PID controller

HD700 has a programmable PID controller. The block diagram is as below:

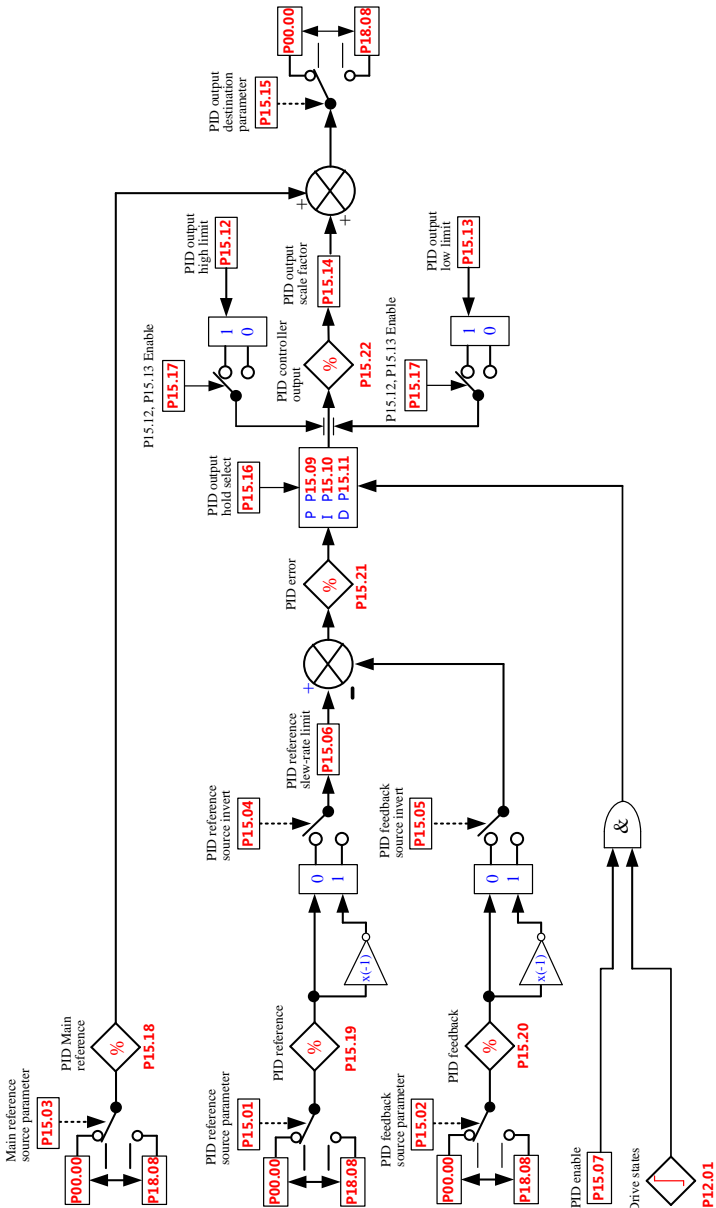

Typical application of PID controller is on the Stress Control, Press Control, Temperature Control, Flow Control, etc.

About parameters of PID controller please refer to the Appendix 2, menu15.

Using PID controller can do the process close-loop control. Following is a simple application example.

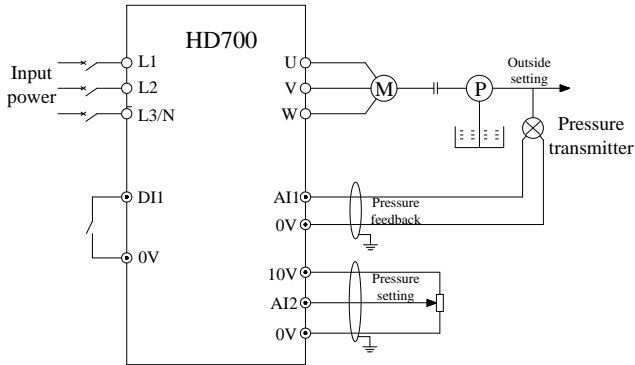

Figure 3-14 Constant water presser control

Setup:

- |                    |   |
|--------------------|---|
| P09.02=3           | DI1 function is run forward                               |
| P00.04 (P01.01) =8 | Reference is user defined                                 |
| P15.15=P01.27      | PID is destined to P01.27 (User defined reference source) |
| P15.01=P01.21      | AI2 is PID reference source (Presser reference)           |
| P15.02=P01.20      | AI1is PID feedback resource (Presser feedback)            |
| P15.07=1           | PID enable  |

## 4 Options

Options	Function
LCD keypad (HDOM-LCD)	Used for operating drives, can display in Chinese and English.
Remote keypad (HDOM-RM-Keypad)	Used for remote operation, the farthest operation distance is 100 meters.
Keypad pallet (HDOM-PadFit)	Used for keypad installation. Connection between the drive and the keypad cannot be more than 10 meters.
Simple keypad pallet (HDOM-PadFit1)	
Communication adapter (HDOM-232)	Can realize the isolate transformation bi-directly between RS-232 and RS-485. HEDY drives can realize high speed data communication with computers through HDOM-232.
Communication adapter (HDOM-USB)	Can realize the isolate transformation bi-directly between USB and RS-485. HEDY drives can realize high speed data communication with computers through HDOM-USB.
Profibus module (HDOM-PROFIBUS-V0)	The HDOM-Profibus-V0 is a fieldbus Solutions Module that can be installed to the expansion slot in HD700 drives to provide PROFIBUS-DP slave connectivity.
PC testing software (HDSOFT (PCTools))	Interactive software (PC tools) between the computer and the drive, convenient and flexible debugging tools, can realize remote operation.
Input and output terminal expansion card (HDOM-IO-Logic)	Can expand the input and output terminals.

## 5 Declaration of conformity

### Declaration of conformity

Guangzhou HEDY Intelligent Equipment Co., Ltd

No.63, Punan Road, Yunpu Industry Zone, Huangpu District, Guangzhou, Guangdong, 510760, China

HD700-20D00040	HD700-20D00075	HD700-20D00150	HD700-20D00220
HD700-20T00400	HD700-40T00075	HD700-40T00150	HD700-40T00220
HD700-40T00400	HD700-40T00550	HD700-40T00750	HD700-40T00220E
HD700-40T00550E	HD700-40T00550P	HD700-40T01100P	HD700-40T01100
HD700-40T01500	HD700-40T01850	HD700-40T02200	HD700-40T03000E
HD700-40T03700E	HD700-40T03000	HD700-40T03700	HD700-40T04500
HD700-40T05500	HD700-41T03000	HD700-41T03700	HD700-41T04500
HD700-41T05500	HD700-40T07500	HD700-40T09000	HD700-40T11000
HD700-40T13200	HD700-41T07500	HD700-41T09000	HD700-41T11000
HD700-41T13200	HD700-60T03000	HD700-60T03700	HD700-60T04500
HD700-60T05500	HD700-61T03000	HD700-61T03700	HD700-61T04500
HD700-61T05500	HD700-60T07500	HD700-60T09000	HD700-60T11000
HD700-60T13200	HD700-61T07500	HD700-61T09000	HD700-61T11000
HD700-61T13200	HD700-40T16000	HD700-60T16000	HD700-41T16000
HD700-61T16000	HD700-40T18500	HD700-60T18500	HD700-41T18500
HD700-61T18500	HD700-40T20000	HD700-60T20000	HD700-41T20000
HD700-61T20000	HD700-40T25000	HD700-60T25000	HD700-41T25000
HD700-61T25000	HD700-40T28000	HD700-60T28000	HD700-41T28000
HD700-61T28000	HD700-40T16000E	HD700-40T18500E	HD700-40T20000E
HD700-60T16000E	HD700-60T18500E	HD700-60T20000E	HD700-41T16000E
HD700-41T18500E	HD700-41T20000E	HD700-61T16000E	HD700-61T18500E
HD700-61T20000E	HD700-40T31500	HD700-40T35500	HD700-40T40000
HD700-40T45000	HD700-41T31500	HD700-41T35500	HD700-41T40000
HD700-41T45000	HD700-60T31500	HD700-60T35500	HD700-60T40000
HD700-60T45000	HD700-61T31500	HD700-61T35500	HD700-61T40000
HD700-61T45000	HD700-40T31500E	HD700-40T35500E	HD700-60T31500E
HD700-60T35500E	HD700-41T31500E	HD700-41T35500E	HD700-61T31500E
HD700-61T35500E			

The AC variable speed drive products listed above have been designed and manufactured in accordance with the following European harmonised standards:

EN 61800-5-1: 2007	Adjustable speed electrical power drive systems — Part 5-1: Safety requirements — Electrical, thermal and energy
EN 61800-3: 2004	Adjustable speed electrical power drive systems — Part 3: EMC requirements and specific test methods
EN 50581:2012	Technical documentation for the assessment of electrical and electronic products with respect to the restriction of hazardous substances

These products comply with the Low Voltage Directive 2006/95/EC, the Electromagnetic Compatibility (EMC) Directive 2004/108/EC, the RoHS2.0 Directive 2011/65/EU and the CE Marking Directive 93/68/EEC.

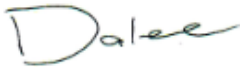

Printed ) Dale Lee

R&D Director

Date: August 26, 2015

These electronic drive products are intended to be used with appropriate motors, controllers, electrical protection components and other equipment to form complete end products or systems. Compliance with safety and EMC regulations depends upon installing and configuring drives correctly, including using the specified input filters. The drives must be installed only by professional assemblers who are familiar with requirements for safety and EMC. The assembler is responsible for ensuring that the end product or system complies with all the relevant laws in the country where it is to be used. Refer to the User Guide. An EMC Data Sheet is also available giving detailed EMC information.



## Drive Repair Card

User information	User corporation:		
	Address:		
	Post code:	Contractor:	
	Tel. no.:	Fax no.:	
Product information	Drive Family:		
	Power size (kW):	S.N.:	
	Contract no.:	Purchase date:	
Repair record	Service engineer:	Tel. no.:	
	Fixed date:		
	Fault information:		
Complaints and demanding on our products:			
User signature:                      year              month              date			
Return visit record:			
Service signature:                      year              month              date			

# Service Agreement

1. Guarantee Free-service period is valid since delivery date from HEDY factory which was subjected to the serial number on the drive rating label.
2. service free for Failure or trouble caused by our product quality issue.
3. For the service that Exceeding Guarantee time or failure not caused by drive quality issues is out of the free range:
  - From inappropriate, negligent or incorrect installation or adjustment of the optional operating parameters of the equipment or from mismatching the drive with the motor;
  - Not permitted by the factory supplier, modified the drive devices;
  - Out of the HD700 product specification application;
  - Failure consequences by fire, flooding, earthquake etc., un-foresee natural disasters;
  - Without drive's serial number or the S.N. can not be identified clearly.
4. Technical support hotline:+86- 4007-000-885



# Default Control Terminal Function

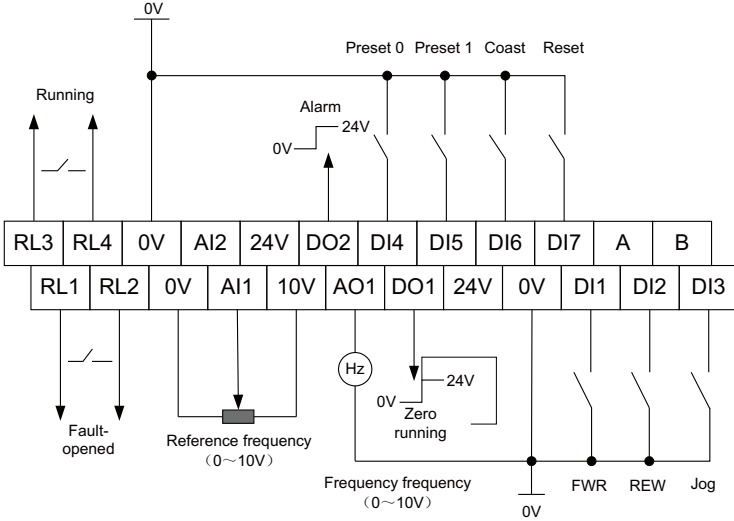

**Guangzhou HEDY Intelligent Equipment Co.,Ltd.**  
**Guangzhou HEDY Industrial Automation Co.,Ltd.**

Add : No.63,Punan Road, Yunpu Industry Zone,Huangpu District,Guangzhou City 510760,China  
 Fax : +86-(0)20-3202 1660  
 Technical Support Hotline : +86-4007 000 885  
 Web Site : <http://www.hedyi.com>

